



Program Level FF&E Guideline for External Design Consultants

Solano Community College District
Fairfield, California

Revised 21 February 2018

TABLE OF CONTENTS

1. Cover Letter
2. Interior Space Guidelines
3. Furniture Standards

Mr. Leigh Sata
Executive Bonds Manager
Solano Community College District
4000 Suisun Valley Road
Fairfield, CA 94534

RE: Furniture Fixtures & Equipment (FF&E) Program Guidelines for External Use

Dear Mr. Sata,

Over the past 9 months, our team has worked very closely with the District's FF&E Committee to develop the various processes and procedures necessary to assure the college of successful results relative to FF&E within the Capital Improvement Program. This program incorporates best practices across the spectrum of FF&E applications, and takes into consideration each constituency involved. Every aspect of these recommendations stems from specific issues encountered by the college in previous projects, and seeks to both resolve those challenges, while providing a more robust and effective physical environment for the users.

The chapters herein reflect the primary direction required by project design teams in order to effectively incorporate FF&E into the planning process of a project. These should be added to the District Standards documentation for reference.

Thank you for the opportunity to be of service to the District, and the taxpayers of your community.

Respectfully,



Stephanie O'Brien
President/CEO



INTERIOR SPACE DESIGN GUIDELINES

REVISED 21 FEBRUARY 2018

INTERIOR SPACE GUIDELINES

TABLE OF CONTENTS

21 February 2018

Introduction	Page 3
General Concerns for All Office Spaces.....	Page 4
Faculty (Full Time) Office Space Narrative	Page 6
Faculty (Full Time) Office Space Layout Options.....	Page 7
Faculty (Adjunct) Office Space Narrative	Page 11
Faculty (Adjunct) Office Space Layout	Page 12
Staff (Full Time) Workstation Space Narrative	Page 13
Staff (Full Time) Workstation Minimum Space Layout	Page 14
Staff (Full Time) Office Space Narrative.....	Page 15
Staff (Full Time) Office Space Layout Options	Page 16
Management & Professional Office Space Narrative.....	Page 18
Management & Professional Office Space Layout Options	Page 19
Administrator Office Space Narrative	Page 21
Administrator Office Space Layout Options	Page 22
Vice President Office Space Narrative	Page 25
Vice President Office Space Layout Options	Page 26
Meeting Room Narrative	Page 28
Typical Classroom Space Narrative	Page 29
Typical Classroom Space Layout Options.....	Page 30
Document Control Record	Page 36

INTRODUCTION

As Solano College prepares for an increase in project activity through the Measure Q Capital Improvement Program, the District tasked the FF&E Committee, comprised of various college administrative, faculty and staff representatives, with providing a design narrative and general layouts of Fixtures, Furniture and Equipment (FF&E) within a variety of common spaces found at the college. The goal was to streamline the design process, reduce “one off” project details, incorporate the principles of Universal Design effectively, and to provide the project user groups with clear and definitive direction regarding the interior spaces of their facilities.

The applications covered in this document include:

- Faculty Offices (Full Time and Adjunct)
- Counseling Faculty and Staff Offices
- Staff Workstations
- Management Offices
- Executive Offices
- Meeting Rooms
- Typical Classrooms

It is the intention of this document to align the needs of FF&E with those of the physical environment. This will allow the built environment to better support the mission, Educational Master Plan and Facilities Master Plan of the college. The following descriptions outline the **minimum** requirements of the physical, functional and technological necessities of modern and efficient administrative and instructional environments. Other areas not covered by this document shall follow the same parameters relative to sizing, power and data receptacles, and the placement of building infrastructure requirements.

GENERAL CONCERNS FOR ALL OFFICE SPACES

Following a review of the office space currently utilized throughout the College, during which issues that impact the Faculty, Staff, Administration and Students were identified, and comparing this information to the State Chancellor's Space Guidelines, the Design Guidelines Planning Group has developed the following requirements intended to be applied to all future project designs, regardless of funding source for the project.

Relative to Full Time Faculty Offices, the committee has determined that the current office space allocation is inadequate for the specified needs. Currently these offices range from 71 to 99 assignable square feet in size. The configurations include doors that open into the room in the older facilities, and doors that open into the hallway or exterior space in the newer buildings. Many older offices include access to closets or service rooms, further limiting their opportunities for furniture placement due to ADA code requirements. And some full time faculty share an office space, which inherently creates issues of privacy and noise levels when speaking with students.

Moving forward, it is the District's intention to standardize these offices to an equitable and sustainable size, and to provide the District with more flexibility for reutilization of spaces. The committee has ensured that these recommendations are consistent with Title 5 and the State Chancellor's Office guidelines. They also reflect best practices across similar colleges.

The following layouts reflect the college's requirements for all future projects. In addition, the placement of faculty offices is requested to be adjacent to where students congregate, to maximize faculty/student interactions.

For all spaces addressed within this document, the proposed space standards reflect the clearances required for the **effective** utilization of Furniture and Equipment within each space. The desired minimum **usable** square footage is noted on each application's narrative and layout options. Additional width or depth within the spaces would be acceptable, particularly in spaces that have intrusive structural elements or in more specialized areas. Please refer to each office type for minimum space recommendations.

The District acknowledges with these Interior Space Design Guidelines that the structural details, such as seismic bracing or columns, and architectural details, including windows, may impact the final layout options available to the end user in specific locations. Each layout option configuration included in this document and offered to end users is intended to provide a minimum of two (2) options after infrastructure issues have been taken into consideration. Any representation of exterior window walls is for reference only and is not intended to drive building design. Power and data receptacle placement within offices are shown with the assumption that **all** walls can accept this infrastructure. It is the District's desire that at least two of the four office walls receive power and data receptacles. However, it is understood that project restrictions may limit that possibility.

In order to effectively support the furniture and equipment requirements of these spaces, the Design Guidelines Planning Group requests that project architects specify that light switches be located immediately adjacent to the doorway on the same wall as the door, within 12" of the door frame or side light. This information will need to be communicated to the contractor responsible for these services in such a way that they accept responsibility for relocating any device that is placed outside of this area within an office.

Should a project architect find that they cannot accommodate one of these minimum requirements, all proposed variations must be presented to the college's Executive Bonds Manager for approval of a revision *prior* to presentation to the Project User Group. The Executive Bonds Manager may convene the FF&E Committee and consult with the Facilities Director, Chief Technology Officer and Dovetail as needed. All modifications must be pre-approved by the District, and any variations are to be project specific, rather than wholesale across the Interior Space Design Guidelines document.

Please note that the District no longer funds individual printers per office, and intends to move toward a strategy that greatly reduces the quantity of non-networked devices (such as stand-alone printers) in individual offices. However, it is understood that several management and confidential personnel must retain this function. In addition, all requirements defined in the District Network Infrastructure Design Standards documentation must be followed, and all concerns or requirements related to IT be directed to both the Executive Bonds Manager and the Chief Technology Officer prior to implementation of any variations.

The following narratives are divided into two categories: building infrastructure (also known as Group I requirements as defined by the State Chancellor's Office), and Fixtures, Furniture and Equipment (also known as FF&E and Group II requirements). This is intended to clarify the expectations of what shall be provided by the building contractor as "CFCI" (Contractor Furnished, Contractor Installed) or potentially "OFCI" (Owner furnished, Contractor Installed), depending upon the items, and those items that will be provided as "OFOI" (Owner furnished, Owner installed). The project architect is responsible for confirming all building infrastructure interface requirements for FF&E (Group II) products following the acceptance of the placement plans by the college.

FACULTY (FULL TIME) OFFICE SPACE NARRATIVE

- Minimum space required: Ninety (90) usable square feet for one (1) person, with a desired minimum width of 9'0" clear, to allow for user flexibility of furniture configuration. See Faculty Office Layout Options A, B & C for additional information.
- Building Requirements (Group I):
 - Exterior Window with Campus Standard Shade.
 - Swing Door with hinge side within 6" of room's perpendicular wall. Side Light to be provided where feasible.
 - Power and Data Receptacles: For flexibility in accommodating alternate furniture configurations over time, one 4-plex power outlet beside a two port data receptacle on each of two opposite walls.
- FF&E Requirements (Group II):
 - Height Adjustable Desk.
 - Storage Credenza.
 - Power Connectivity at Worksurface for BYOD Access.
 - Storage Tower with Wardrobe.
 - Binder/Book Storage.
 - Ergonomic Task Chair on Casters.
 - Visitor Chair.
 - Computer with CPU, Two Monitors on Arm, Mouse and Keyboard.
 - Phone Handset.

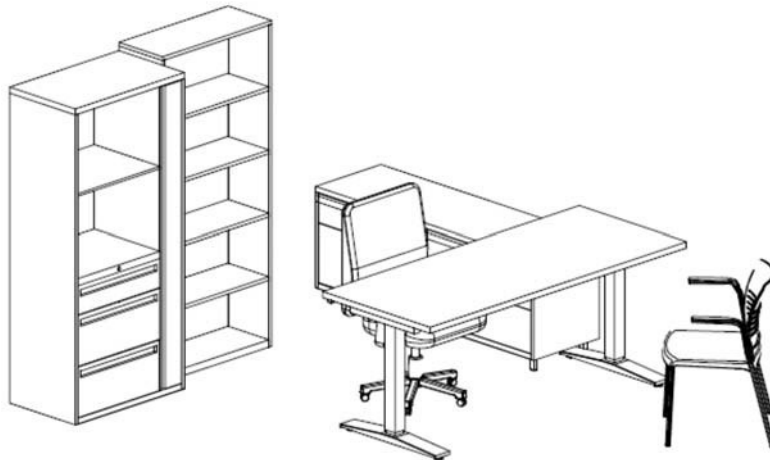
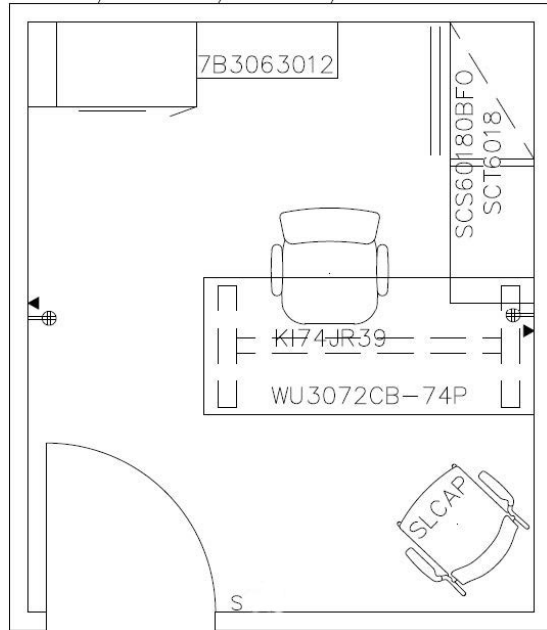

PLAN & ISOMETRIC VIEWS
(Not to Scale)

Solano College Space Standards
Faculty Office Layout A Details
Date: 21 February 2018

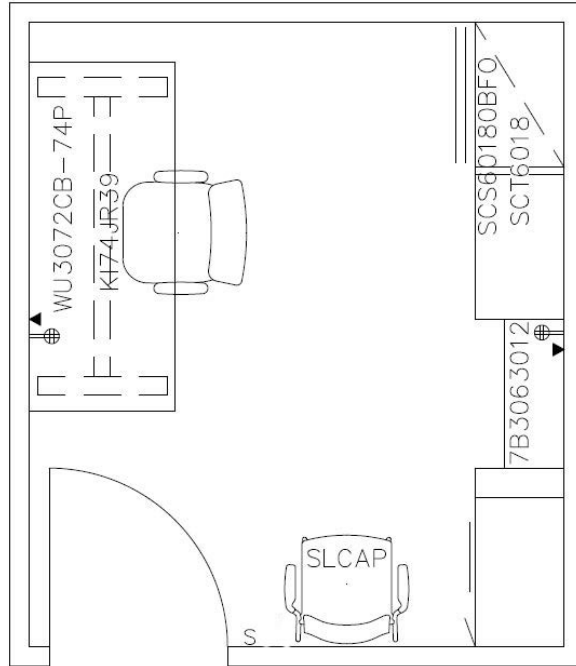

PLAN & ISOMETRIC VIEWS
(Not to Scale)

Solano College Space Standards
Faculty Office Layout B Details
Date: 21 February 2018

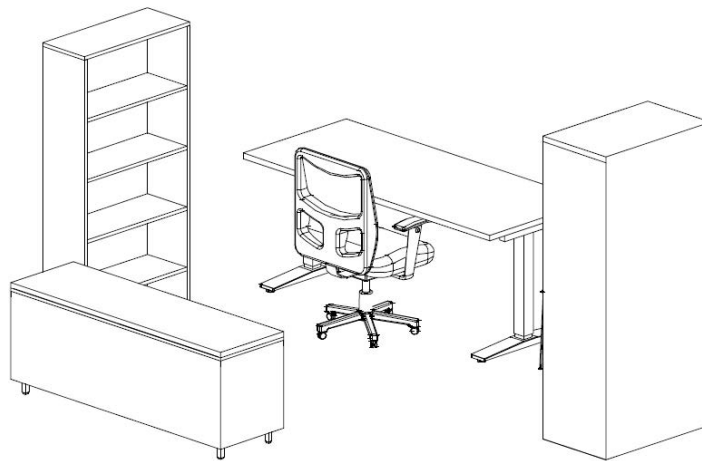
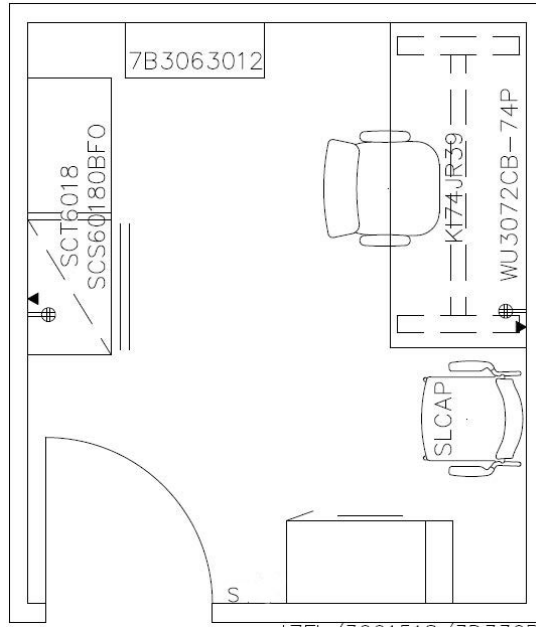

PLAN & ISOMETRIC VIEWS
(Not to Scale)

Solano College Space Standards
Faculty Office Layout C Details
Date: 21 February 2018

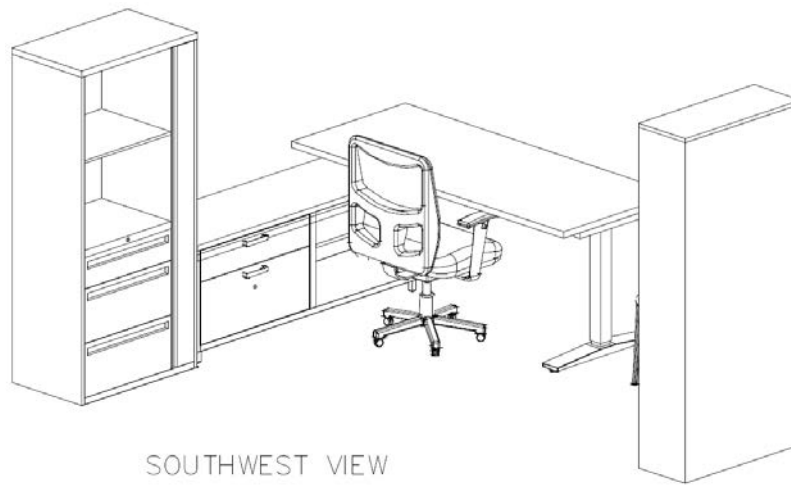
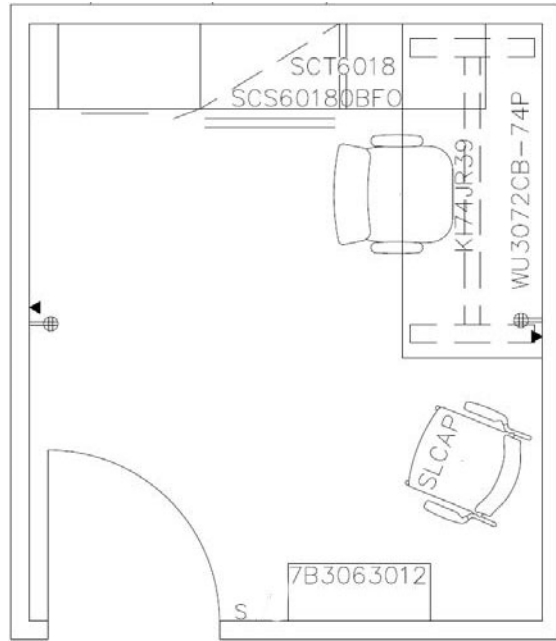

PLAN & ISOMETRIC VIEWS
(Not to Scale)

Solano College Space Standards
Faculty Office Layout D Details
Date: 21 February 2018

FACULTY (ADJUNCT) OFFICE SPACE NARRATIVE

- Minimum space required: Two Hundred (200) ASF, in “Hoteling” configurations. See Adjunct Faculty Office Layout for general configuration and information. These spaces will provide four (4) “hoteling” type stations, and will be assigned to a variety of Adjunct per department.
- Building Requirements (Group I):
 - Wireless Access for User Devices and Wireless Printing.
 - Power and Data Receptacles: One (1) 4-plex power receptacle beside each data receptacle, placed one (1) per station. See Adjunct Faculty Layout for desired placement. See current District Network Infrastructure Design Standards for current configuration of data receptacles.
 - Access to Collaborative Space for Student Discussion.
 - Adjacent to Student Gathering Locations.
- FF&E Requirements (Group II):
 - Minimum of 10 Sq. Ft. of Freestanding Worksurface, Height Adjustable.
 - Power Connectivity at Worksurface for BYOD Access.
 - Ergonomic Task Chair with casters, per station.
 - Personal Storage Locker Unit, per person.
 - Computer with CPU, Monitor, Mouse and Keyboard (one per station).
 - Access to Networked Printer.
 - Phone Handset (one per station).

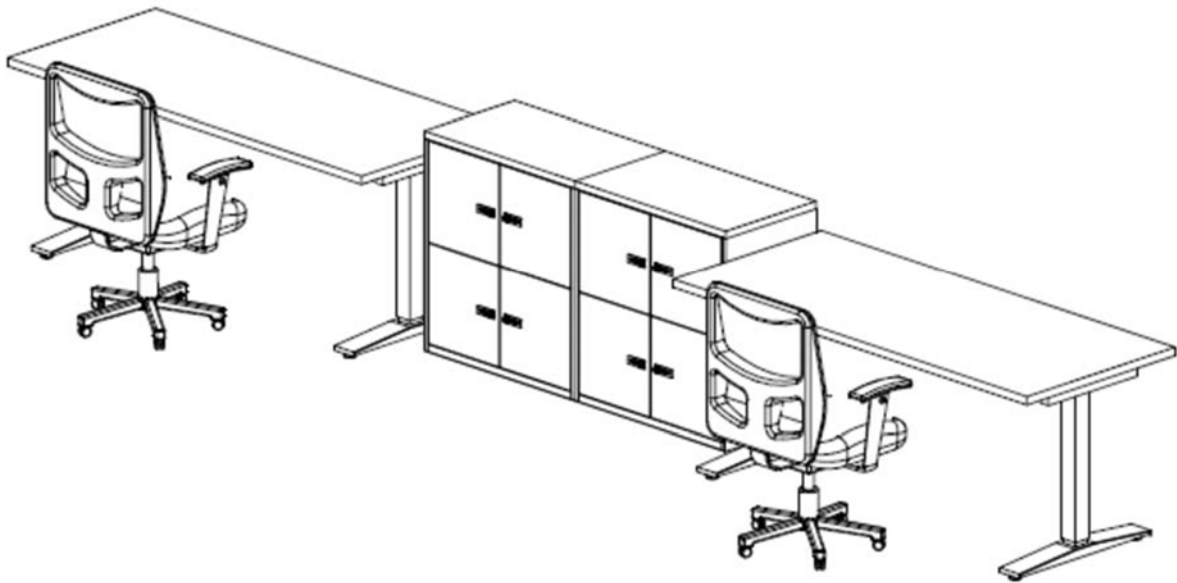
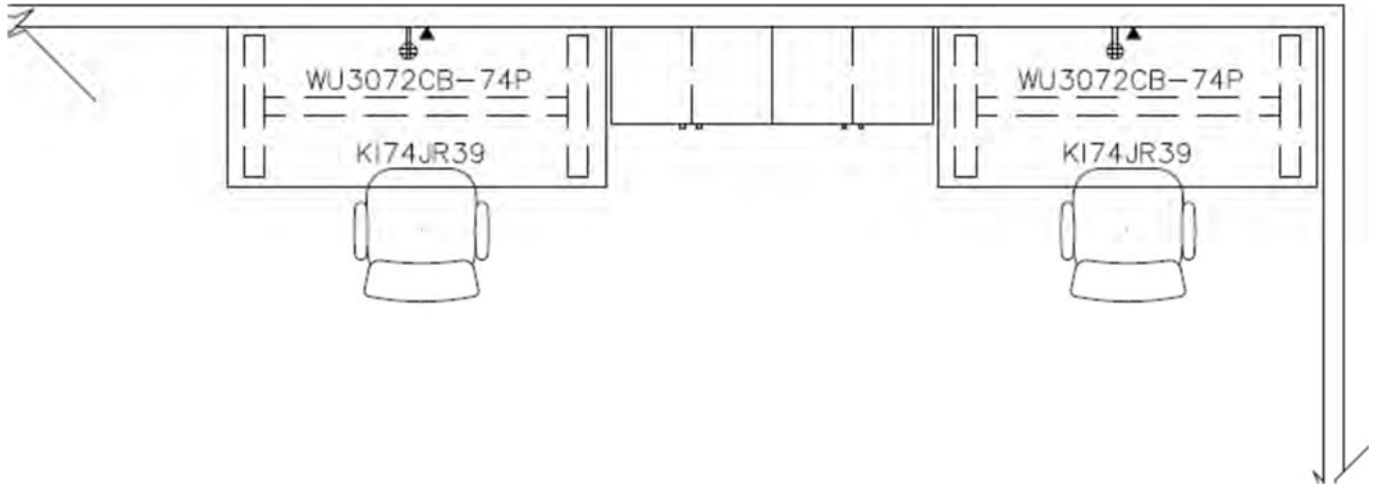

PLAN & ISOMETRIC VIEWS
(Not to Scale)

Solano College Space Standards
Adjunct Shared Office Details
Date: 21 February 2018

STAFF (FULL TIME) WORKSTATION NARRATIVE

- Minimum space required: Sixty-four (64) usable square feet for one (1) person, plus appropriate circulation and access to required storage space. See Staff Workstations Open Office Area Layout for additional information.
- Building Requirements (Group I):
 - Power and Data connections: Circuitry to support a minimum of four (4) duplex receptacles per workstation. See current District Network Infrastructure Design Standards for current configuration of data receptacles.
- FF&E Requirements (Group II):
 - Panel Surround with Power and Data Receptacles.
 - Height Adjustable Desk with Return or Extension.
 - Power Connectivity at Worksurface for BYOD Access.
 - Credenza Surface with Storage Below.
 - Storage Pedestal.
 - Ergonomic Task Chair on Casters.
 - File Storage (see layout for product types).
 - Overhead Storage with Task Lighting.
 - Computer with Tower CPU, Two Monitors, Mouse and Keyboard.
 - Phone Handset.
 - Access to Networked Printer.
 - Access to additional storage as required by position.

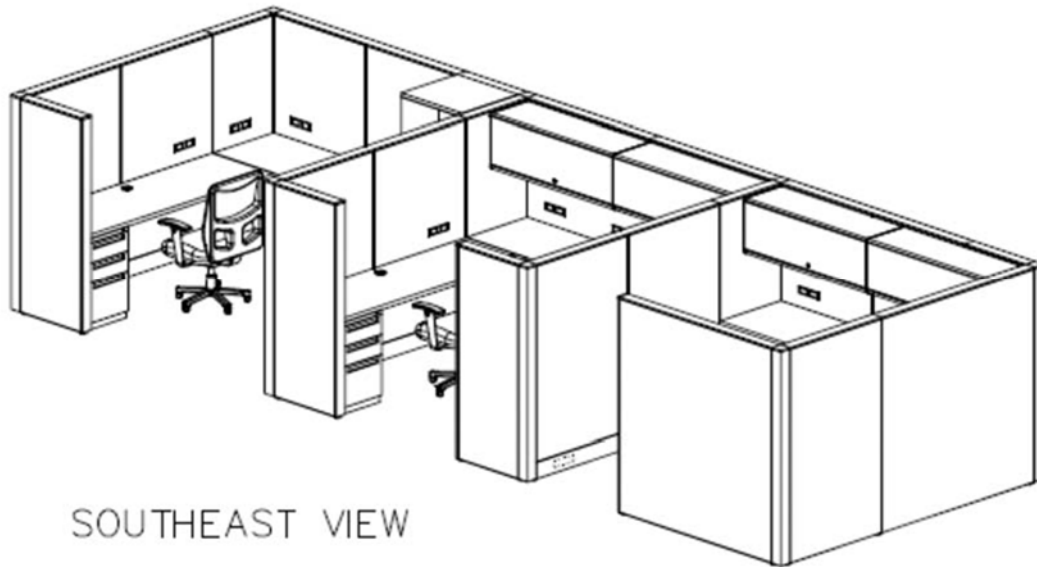
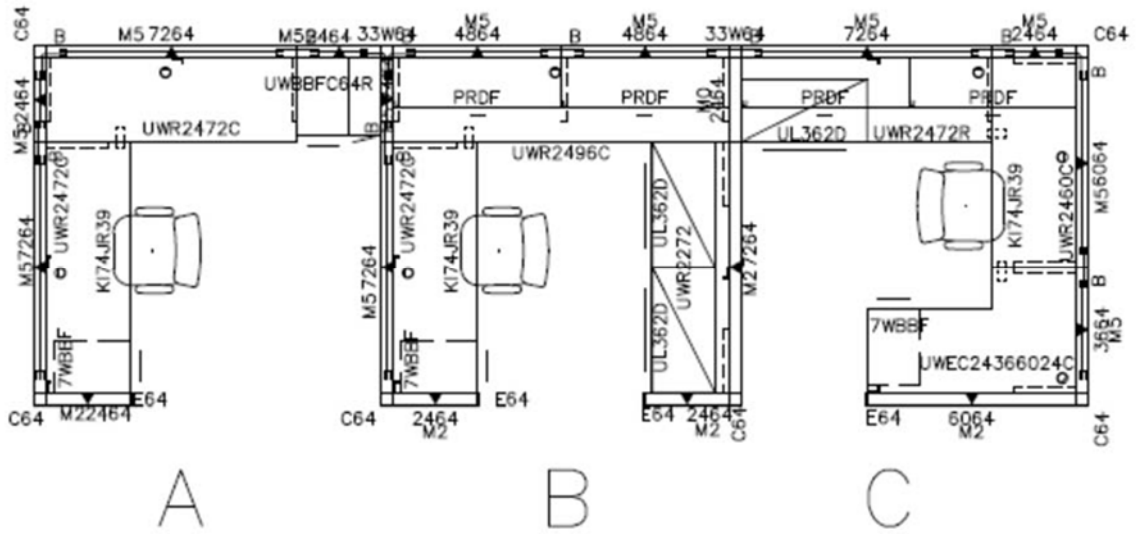

PLAN & ISOMETRIC VIEWS
(Not to Scale)

Solano College Space Standards
Staff Workstation Layout Option Details
Date: 21 February 2018

STAFF (FULL TIME) OFFICE SPACE NARRATIVE

- Minimum space required: One Hundred (100) usable square feet for one (1) person, with a desired minimum width of 9'0" clear to allow for user flexibility of furniture configuration. See Full Time Staff Office Layout Options A & B for additional information.
- Building Requirements (Group I):
 - Swing Door with hinge side within 6" of room's perpendicular wall. Side Light to be provided where feasible.
 - Backing behind sheetrock on full length of walls perpendicular to window and door wall, to support Group II, horizontally mounted overhead cabinets or accessories. See Full Time Staff Office Layout Options A & B for possible placement of units for reference.
 - Power and Data Receptacles: For flexibility in accommodating alternate furniture configurations over time, one 4-plex power outlet beside a two port data receptacle on each of two opposite walls.
- FF&E Requirements (Group II):
 - Height Adjustable Desk with Return or Extension.
 - Power Connectivity at Worksurface for BYOD Access.
 - Mobile Storage Pedestal.
 - Ergonomic Task Chair on Casters.
 - Rail Hung Whiteboard or Tackboard.
 - File Storage.
 - Binder/Book Storage.
 - Overhead Storage with Hanging Tack Board and Task Light.
 - (2) Visitor Chairs.
 - Computer with CPU, Two Monitors, Mouse and Keyboard.
 - Phone Handset.
 - Local Printer or access to Networked Printer.

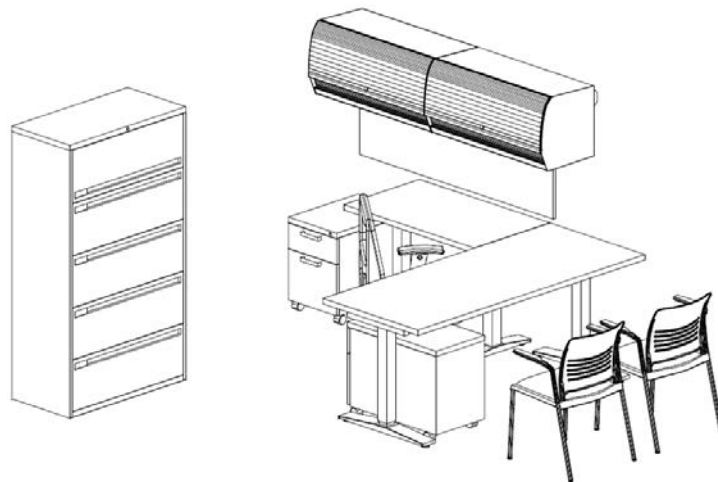
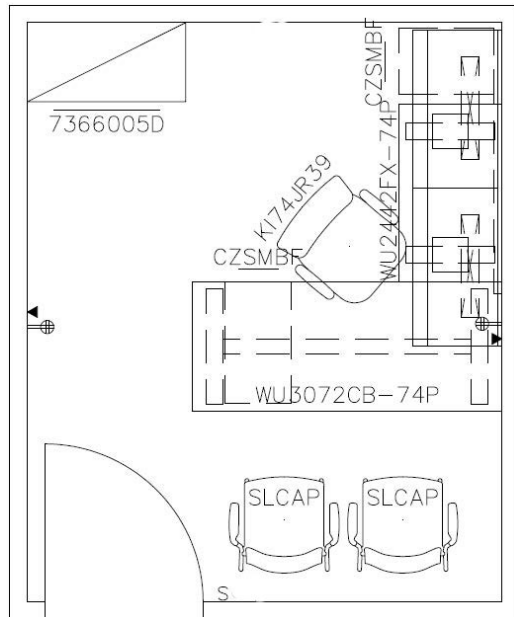

PLAN & ISOMETRIC VIEWS
(Not to Scale)

Solano College Space Standards
Staff Office Layout A Details
Date: 21 February 2018

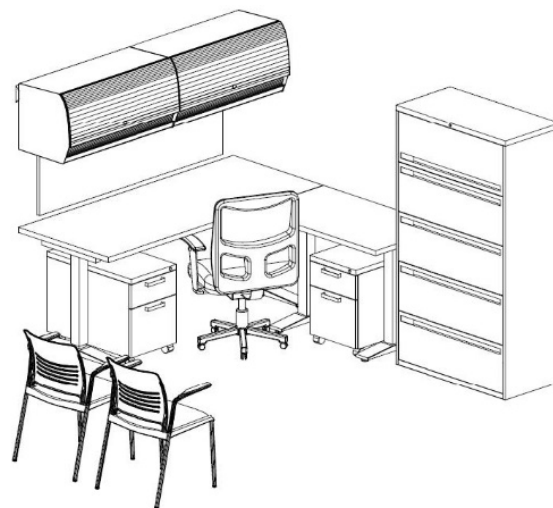
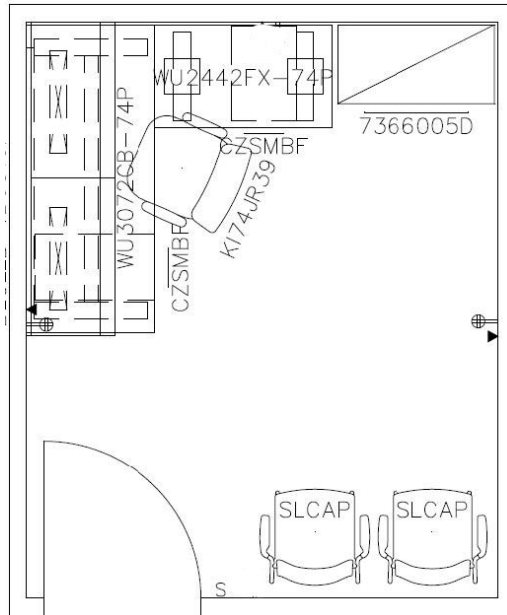

PLAN & ISOMETRIC VIEWS
(Not to Scale)

Solano College Space Standards
Staff Office Layout B Details
Date: 21 February 2018

MANAGEMENT & PROFESSIONAL OFFICE SPACE NARRATIVE

- Minimum space required: One hundred twenty (120) usable square feet for one (1) person, with a desired minimum width of 10'0" clear to allow for user flexibility of furniture configuration. See Management & Professional's Office Layouts A & B for additional information.
- Building Requirements (Group I):
 - Swing Door with hinge side within 6" of room's perpendicular wall. Side Light to be provided where feasible.
 - Backing behind sheetrock on full length of walls perpendicular to window and door wall, to support Group II, horizontally mounted overhead cabinets or accessories. See Management & Professional's Office Layouts A & B for possible placement of units for reference.
 - Power and Data Receptacles: For flexibility in accommodating alternate furniture configurations over time, one 4-plex power outlet beside a two port data receptacle on each of two opposite walls.
- FF&E Requirements (Group II):
 - Height Adjustable Desk with Return or Extension.
 - Power Connectivity at Worksurface for BYOD Access.
 - Credenza Surface with Storage Below.
 - Storage Pedestal.
 - Ergonomic Task Chair on Casters.
 - Rail Hung Whiteboard or Tackboard.
 - File Storage.
 - Overhead Storage with Hanging Tack Board and Task Light.
 - (2) Visitor Chairs.
 - Computer with Tower CPU, Two Monitors, Mouse and Keyboard.
 - Phone Handset.
 - Local Printer.

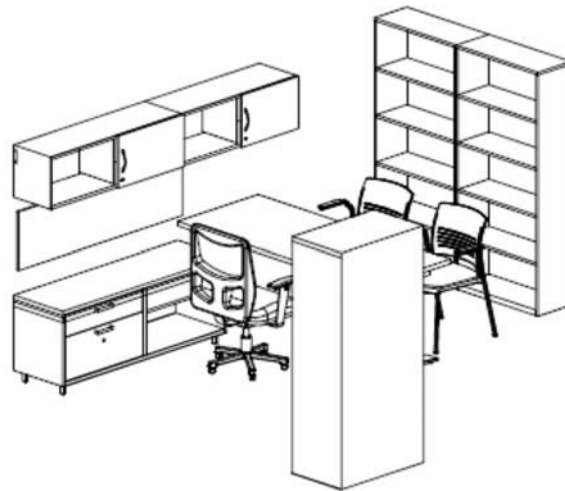
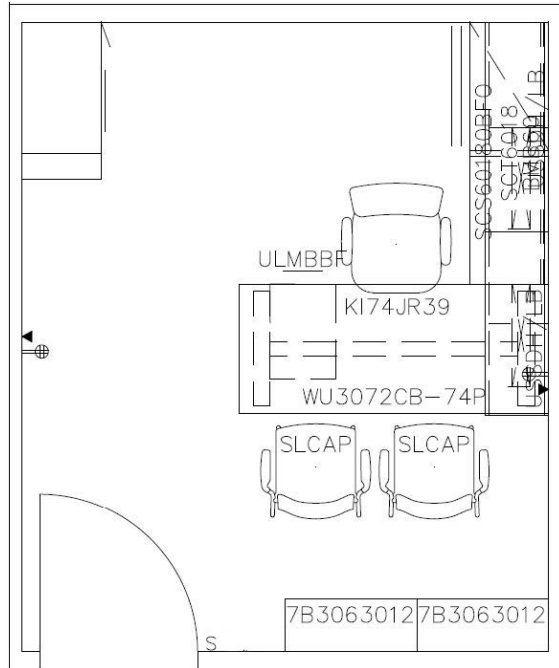

PLAN & ISOMETRIC VIEWS
(Not to Scale)

Solano College Space Standards
 Management & Professional Staff Layout A Details
 Date: 21 February 2018

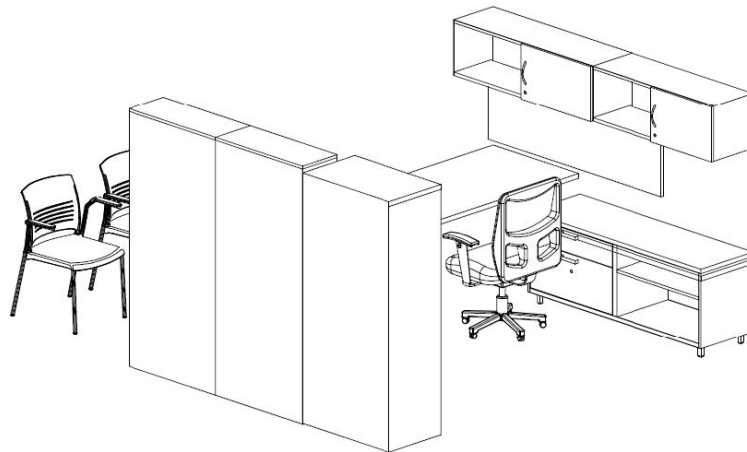
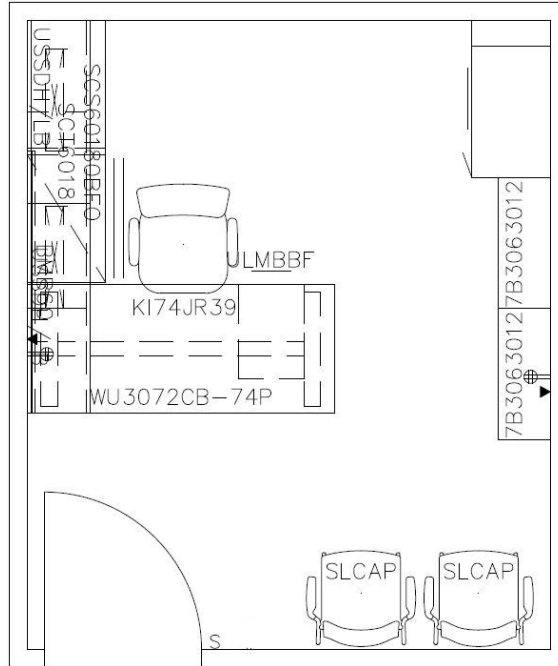

PLAN & ISOMETRIC VIEWS
(Not to Scale)

Solano College Space Standards
Management & Professional Staff Layout B Details
Date: 21 February 2018

ADMINISTRATOR OFFICE SPACE NARRATIVE

- Minimum space required: One hundred forty (140) usable square feet for one (1) person, with a desired minimum width of 10'0" clear to allow for user flexibility of furniture configuration. See Senior Management Office Layout A for additional information.
- Building Requirements (Group I):
 - Swing Door with hinge side within 6" of room's perpendicular wall. Side Light to be provided where feasible.
 - Power and Data Receptacles: For flexibility in accommodating alternate furniture configurations over time, one 4-plex power outlet beside a two port data receptacle on each of two opposite walls.
- FF&E Requirements (Group II):
 - Height Adjustable Peninsula Desk with Return.
 - Power Connectivity at Worksurface for BYOD Access.
 - Storage Credenza.
 - Storage Pedestal.
 - Ergonomic Task Chair on Casters.
 - Rail Hung Whiteboard or Tackboard.
 - File Storage.
 - Binder/Book Storage.
 - Overhead Storage with Hanging Tack Board and Task Light.
 - (4) Visitor Chairs.
 - Computer with CPU, Two Monitors, Mouse and Keyboard.
 - Phone Handset.
 - Local Printer.

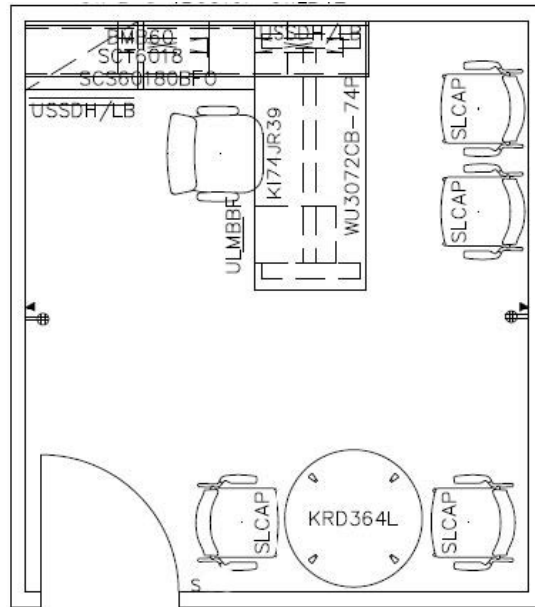

PLAN & ISOMETRIC VIEWS
(Not to Scale)

Solano College Space Standards
Administrator Office Layout B Details
Date: 21 February 2018

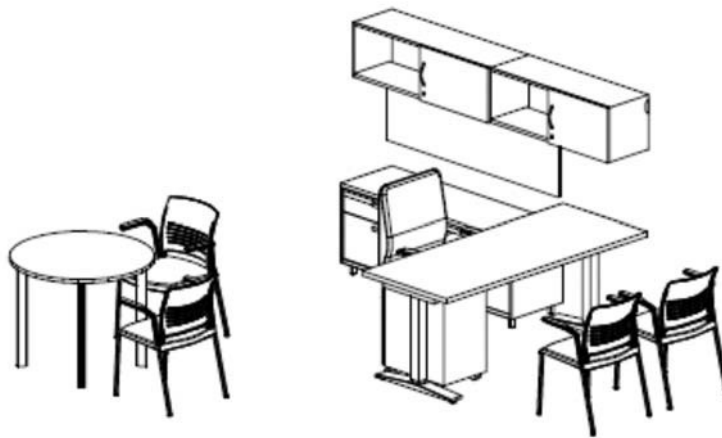
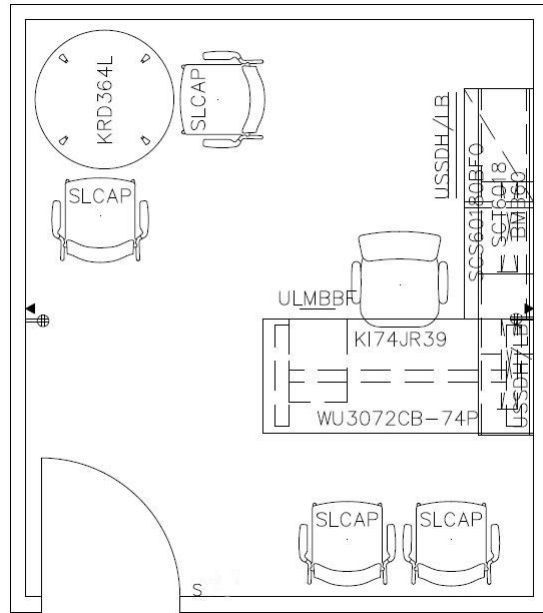

PLAN & ISOMETRIC VIEWS
(Not to Scale)

Solano College Space Standards
Administrator Office Layout C Details
Date: 21 February 2018

VICE PRESIDENT OFFICE SPACE NARRATIVE

- Minimum space required: Two hundred twenty (220) usable square feet for one (1) person, with a desired minimum width of 12'0" clear to allow for user flexibility of furniture configuration. See Vice President Office Layouts A & B for additional information.
- Building Requirements (Group I):
 - Swing Door with hinge side within 6" of room's perpendicular wall. Side Light to be provided where feasible.
 - Power and Data Receptacles: For flexibility in accommodating alternate furniture configurations over time, one 4-plex power outlet beside a two port data receptacle on each of two opposite walls. Power outlets other walls as required by code.
- FF&E Requirements (Group II):
 - Height Adjustable Peninsula Desk with Return.
 - Power Connectivity at Worksurface for BYOD Access.
 - Storage Credenza.
 - Storage Pedestal.
 - Ergonomic Task Chair on Casters.
 - Wall Mounted White Board.
 - Wall Mounted Tack Board.
 - (30) Lineal Feet of Multimedia Storage (see layout for product types).
 - Potential for Overhead Storage with Task Lighting.
 - Meeting Table with (4) Visitor Chairs.
 - Computer with Tower CPU, Two Monitors, Mouse and Keyboard.
 - Phone Handset.
 - Local Printer.

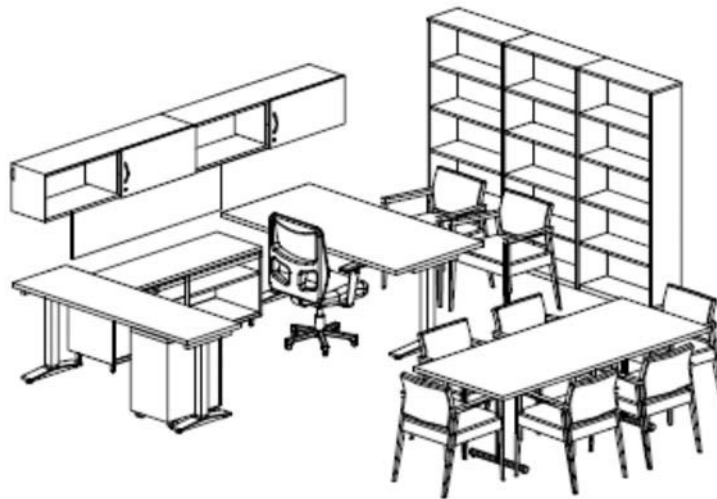
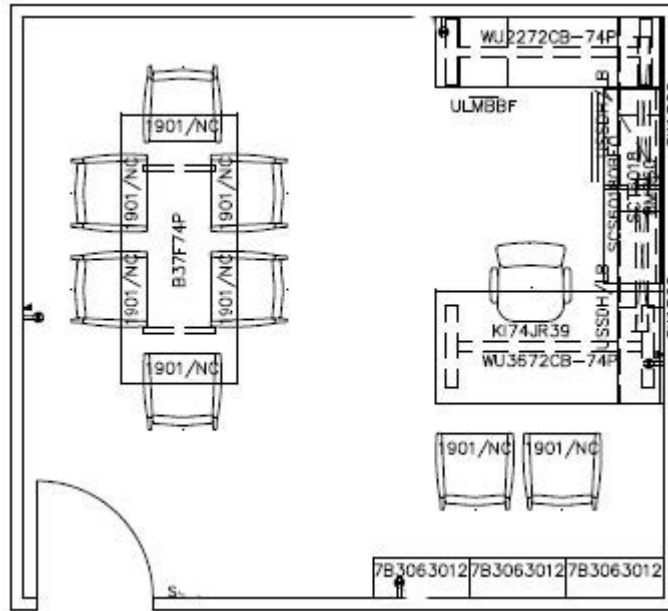

PLAN & ISOMETRIC VIEWS
(Not to Scale)

Solano College Space Standards
Vice President Office Layout A Details
Date: 21 February 2018

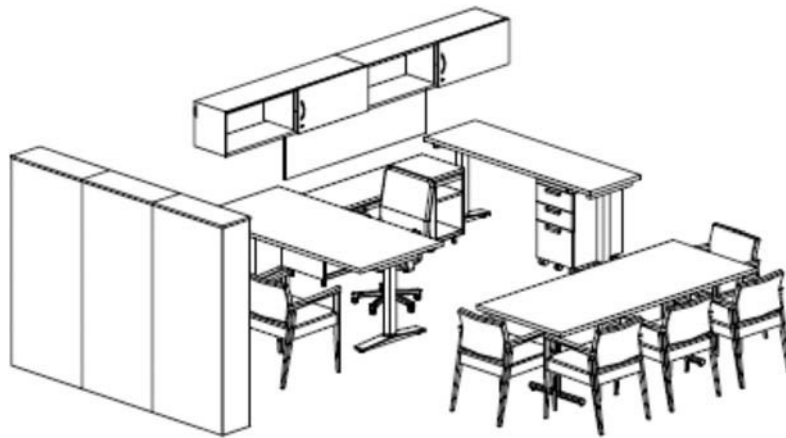
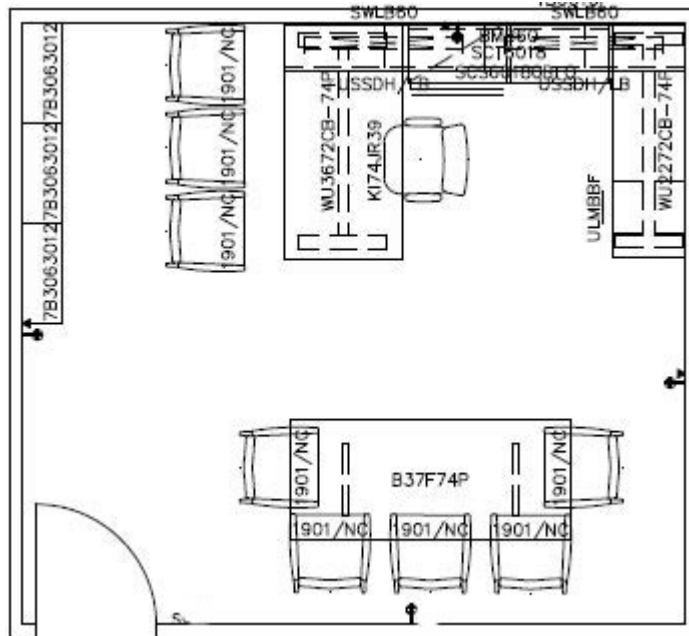

PLAN & ISOMETRIC VIEWS
(Not to Scale)

Solano College Space Standards
Vice President Office Layout B Details
Date: 21 February 2018

MEETING ROOM NARRATIVE

- Minimum space required: Small Meeting Rooms shall be planned for 4 to 6 occupants at (120) usable square feet; Medium Meeting Rooms shall be planned for 10 to 12 occupants at (240) usable square feet; Large Meeting Rooms shall be planned for up to 20 occupants at (400) usable square feet. For small and medium meeting rooms, anticipate future utilization for other needs, such as office space, storage facilities or other possible occupancies.
- Building Requirements (Group I):
 - Exterior Window (preferred) with Campus Standard Shade.
 - Door, Locking, with Side Light.
 - Power and Data receptacles: For flexibility in accommodating alternate furniture configurations over time, one 4-plex power outlet beside a two port data receptacle on each of two opposite walls. Power outlets other walls as required by code.
 - For medium and large rooms, confirm connectivity presentation capability requirements per application.
- FF&E Requirements (Group II):
 - Meeting Table sized appropriately for occupancy (for rectangular shapes, number of occupants dictates length of table).
 - Seating for room occupancy.
 - Storage Credenza.
 - Wall Mounted White Boards.
 - Phone Handset.
 - For all rooms, confirm presentation equipment requirements.

TYPICAL CLASSROOM SPACE NARRATIVE

Classrooms represent the largest user of space within the college, as well as the area in most need of flexibility as pedagogies evolve. The classroom spaces reflected within this document at this time are intended to be a placeholder, to provide general direction for the physical requirements, with the understanding that the college is undertaking an initiative to develop the “21st Century Classroom”. The results of this inquiry will be added to the Interior Space Design Guidelines at the conclusion of the various college committee’s process.

- Minimum space required: Nine hundred fifty (950) square feet of space, with minimum of three product type configurations. See Classroom Layouts for Tablet Desks, Tables and 360 Desks for possible configurations.
- Building Requirements (Group I):
 - Exit door opening into hallway.
 - Appropriate “daylighting” to meet LEED Silver requirements.
 - Appropriate window coverings to manage AV requirements.
 - Lighting controls located near Faculty Station.
 - Two “front of room” connection locations for Faculty Media controls.
 - Minimum of seven (7) feet depth from teaching wall to first row of students for Faculty at front of room.
 - Minimum of sixty (60) feet steel backed porcelain white board (two walls). See District Standards for manufacturer and detail.
 - See current District Network Infrastructure Design Standards for current configuration of data receptacles.
 - Potential to divide room into two smaller classrooms in future (would require two (2) exit doors. Confirm requirement during programming with college.
- FF&E Requirements (Group II):
 - Seating for minimum of thirty-five (35) students in Tables/Chairs configuration.
 - Faculty Desk and Chair.
 - AV Media Storage Unit and/or Podium. See current Furniture Standards for details and connectivity requirements.

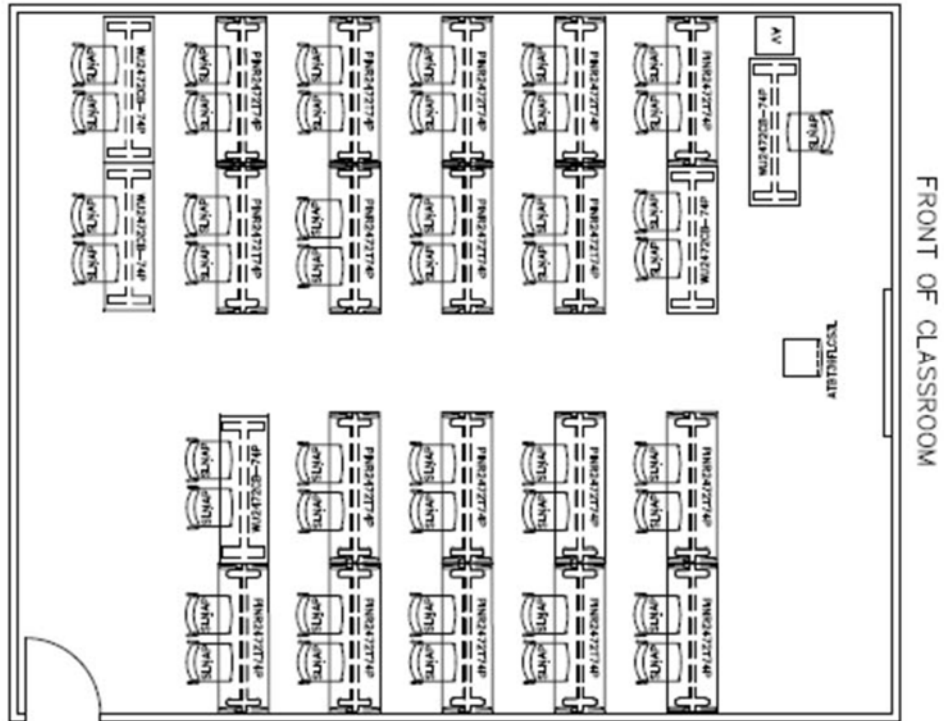

CONFIGURATION REFLECTS (44) STUDENTS, INCLUDING (2) ADA

**PLAN VIEW
(Not to Scale)**

Solano College Space Standards
 Classroom Configuration Details – Tables & Chairs
 Date: 21 February 2018

FRONT OF CLASSROOM

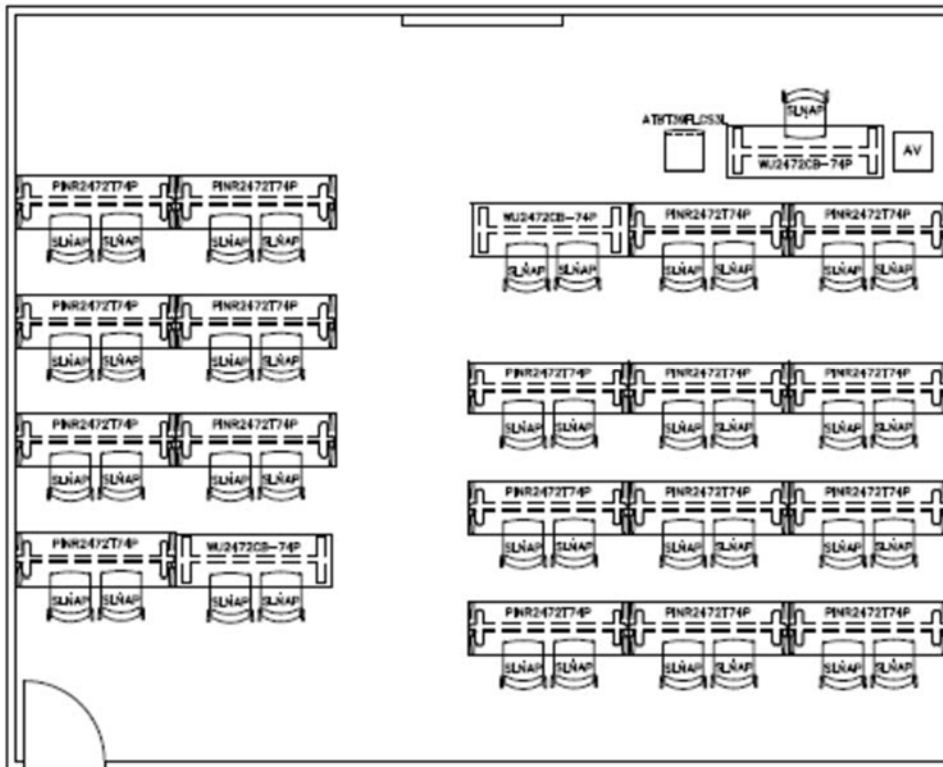

CONFIGURATION REFLECTS (40) STUDENTS, INCLUDING (2) ADA

PLAN VIEW
(Not to Scale)

Solano College Space Standards
Classroom Configuration Details – Tables & Chairs
Date: 21 February 2018

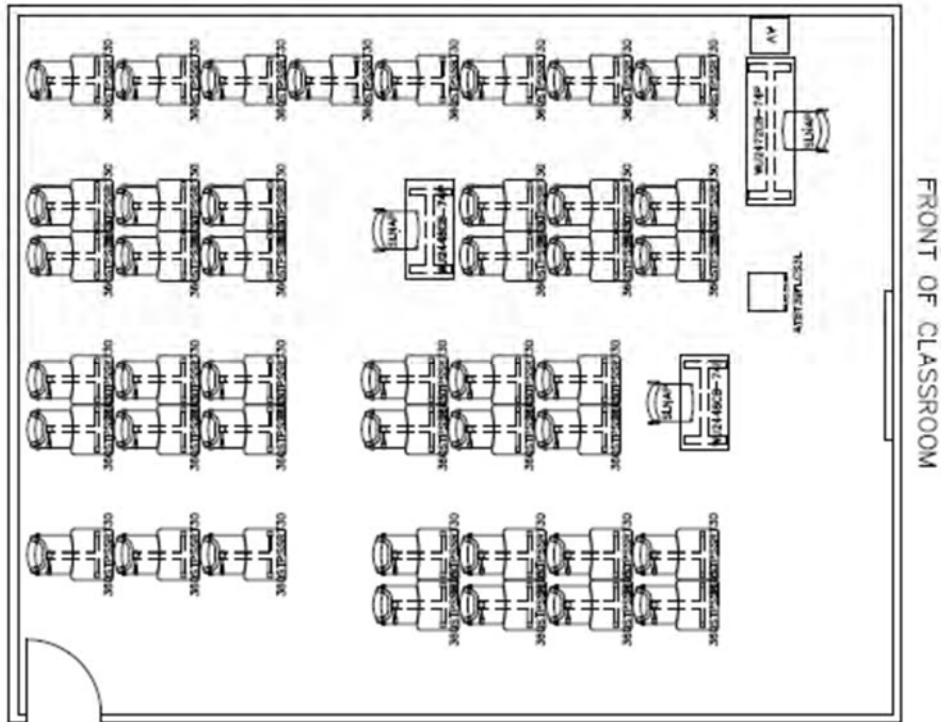

CONFIGURATION REFLECTS (45) STUDENTS, INCLUDING (2) ADA

PLAN VIEW
(Not to Scale)

Solano College Space Standards
Classroom Configuration Details – Traditional Student Desks
Date: 21 February 2018

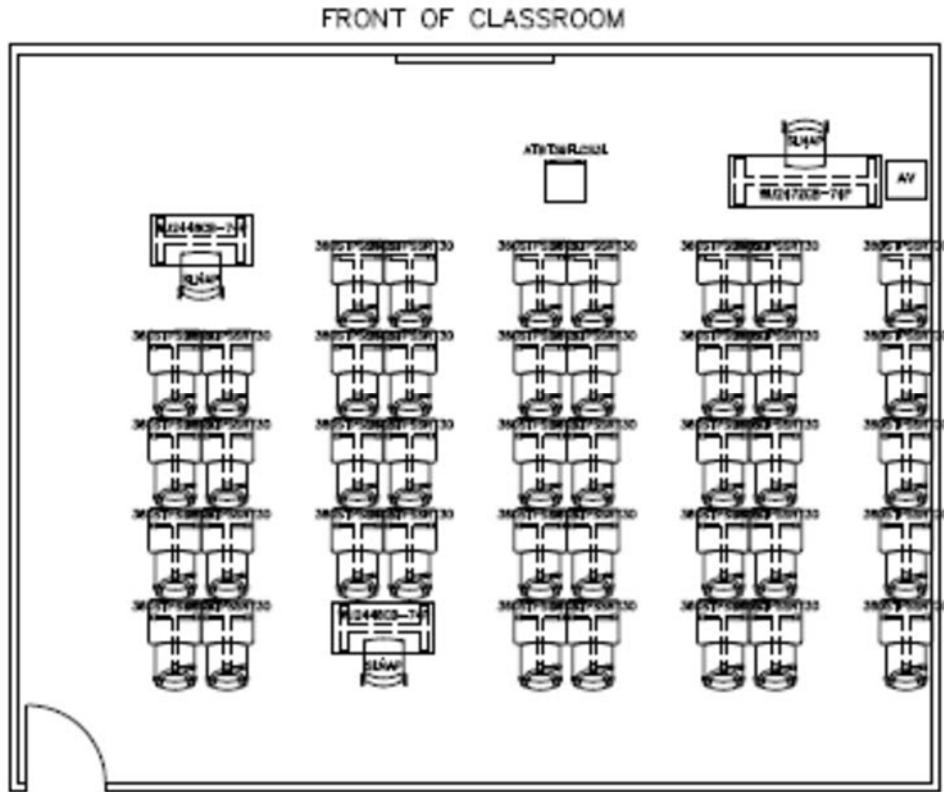

CONFIGURATION REFLECTS (43) STUDENTS, INCLUDING (2) ADA

PLAN VIEW
(Not to Scale)

Solano College Space Standards
 Classroom Configuration Details – Traditional Student Desks
 Date: 21 February 2018

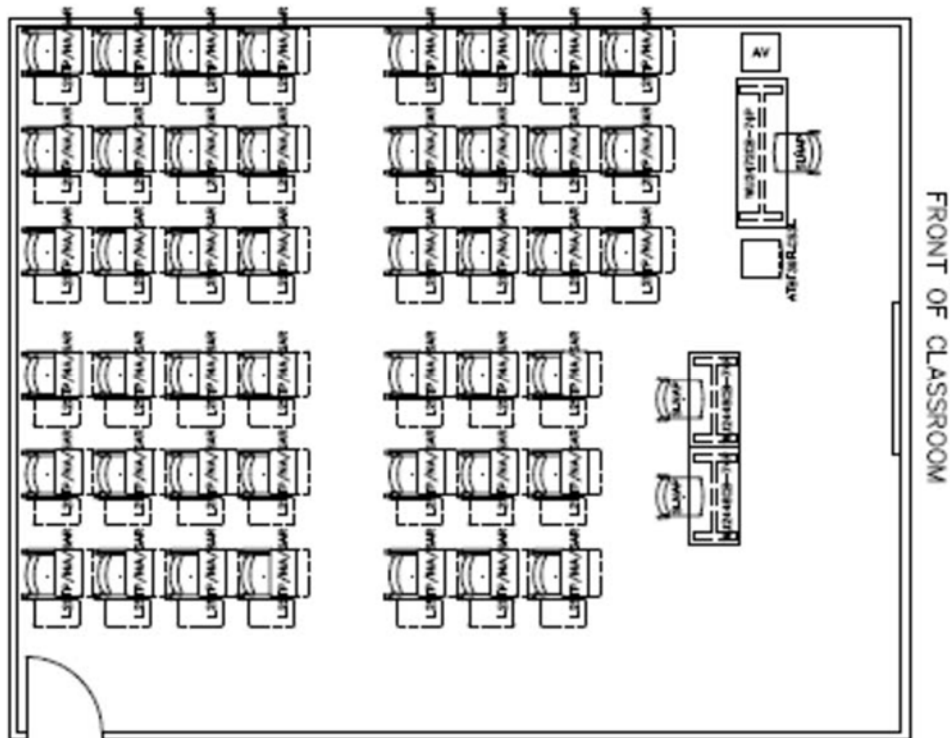

CONFIGURATION REFLECTS (47) STUDENTS. INCLUDING (2) ADA

PLAN VIEW
(Not to Scale)

Solano College Space Standards
Classroom Configuration Details – Dynamic Student Desks
Date: 21 February 2018

FRONT OF CLASSROOM



CONFIGURATION REFLECTS (47) STUDENTS, INCLUDING (2) ADA

PLAN VIEW
(Not to Scale)

Solano College Space Standards
Classroom Configuration Details – Dynamic Student Desks
Date: 21 February 2018

**DOCUMENT CONTROL RECORD
SOLANO INTERIOR SPACE GUIDELINES**

REVISION NUMBER	BY	DATE	KEY CHANGES
Original	FF&E Committee	6/19/15	NA
1	Board of Trustees	2/21/18	NA
2			
3			
4			
5			
6			
7			
8			
9			
10			
11			
12			
13			
14			
15			
16			
17			
18			
19			
20			



FURNITURE STANDARDS PROGRAM

REVISED 21 FEBRUARY 2018

FURNITURE STANDARDS PROGRAM

TABLE OF CONTENTS

Introduction	Page 3
Processes for Utilization.....	Page 4
Performance Specifications.....	Page 6
Furniture Application Matrix	Page 7
Individual Selections Forms for Faculty, Staff Offices.....	Page 9
Academic Applications Product Sheets	Page 11
Administrative Applications Product Sheets.....	Page 23
Specialty and Common Area Product Sheets.....	Page 38
Document Control Record.....	Page 48

Appendix I: Complete Performance Specifications

Appendix II: Furniture Vendor Complete Response to Requirements

Appendix III: Performance Specification Questionnaire for Specialty Items

Appendix IV: Furniture Vendor Contract Details

INTRODUCTION

Solano College is preparing for an increase in project activity through the Measure Q Capital Improvement Program, as well as new funding for Instructional Equipment from the state. The District tasked the FF&E Committee, comprised of various stakeholders, with creating a practical and effective selection of furniture to address a variety of common spaces found at the college. The goals were many: develop an appropriate collection of products from which to select, reduce the individualization of buildings, increase District buying power, reduce operational expenses over time, and provide the tools to address the rapidly changing learning environment.

The applications covered in this document include:

- Student and Faculty Seating for Classrooms, Labs and Computer Rooms
- Student and Faculty Tables for Classrooms, Computer Rooms and General Applications
- Faculty and Staff Office Desking, Storage and Seating
- Staff Workstations
- Meeting Rooms Seating and Tables
- Public Area Seating and Tables

Over the course of several months during the spring semester of 2015, the committee met twice a month to delve into the reoccurring issues that surround furniture within the college environment. This information was prioritized as it relates to fiscal and student success implications, which was then translated into performance specifications. These were used as the benchmark against which all potential products would be evaluated. The committee used a performance-based evaluation process, dissecting each product in a thorough manner to ascertain its viability. The results are contained herein.

This program is intended align the needs of the overall FF&E products procured by the District with those of the faculty, staff and students. This will allow the college to better support their mission, Educational Master Plan and Facilities Master Plans.

While the program does not include every application of furniture that may be found within the campus environment, the following information outline the minimum requirements of the items identified as typical or common, while providing a process for effectively evaluating atypical or specialty items. As part of their objectives, the college strives to institutionalize the processes and protocols of this key aspect of the physical environment, allowing the faculty and staff to focus on their primary responsibilities.

PROCESSES FOR UTILIZATION

Providing the proper tools for faculty, staff and students to excel is a key objective of the college. This program provides a cohesive and appropriate selection of furniture to support this goal, and engages vendors to provide the necessary services to make all items fully functional upon delivery to the college. In addition, the performance expectations defined through this program reflect the overarching requirements, regardless of application or funding, for all furniture, fixtures and instructional equipment procured through the District.

In order to maintain the effectiveness of this program, it was important to define processes for how the college community will utilize and maintain the program. Following the recommendations of the Strategic Sourcing Protocol, these procedures assume that the products being procured are available from existing Public Contract Code compliant, “piggybackable” contracts offering the items evaluated and selected by the FF&E Committee, including the full complement of services required to make these products fully operational for the college.

PROGRAM UTILIZATION

For day-to-day requirements within the college’s programs and support departments, the following protocol will be utilized:

Vice President	Request requirements from Deans/Directors; approve final product and finish requests; confirm funding mechanism; assure compliance with program
Dean/Director	Select items from Standards Program to meet program needs; identify quantities needed; prepare requisitions
Individual Users	Advise Dean/Director on program requirements, assist in selection of appropriate product requirements
Procurement	Manage vendor purchase orders
Facilities	Confirm selection of glides, casters and other surface-marring details are appropriate for flooring condition; coordinate disposition of existing items on campus to provide space for the new items; manage warranty service requirements with vendors

For capital improvement projects, the following protocol will be followed:

Program Manager	Manage funding to address program needs; arrange appropriate level of coordination with project design team; develop requisitions for project requirements; manage implementation process to achieve project timing requirements
-----------------	--

Vice President	Request requirements from Deans/Directors; approve final product and finish requests; assure compliance with program
Dean/Director	Select items from Standards Program to meet program needs; identify quantities needed
Individual Users	Advise Dean/Director on program requirements, assist in selection of appropriate product requirements
Bond Procurement	Issue and manage vendor purchase orders
Facilities	Confirm selection of glides, casters and other surface-marring details are appropriate for flooring condition; confirm new non-standard items meet building and service expectations; manage warranty service requirements with vendors

PERFORMANCE SPECIFICATIONS

A primary objective of this program was to define the expectations of all furniture items procured by the college. Using a facilitated, structured process, the committee reviewed the most impactful challenges within the physical environment, defined which issues needed to be addressed, and developed and prioritized these into Performance Specifications. The committee intentionally avoided some of the more basic criteria often used to evaluate furniture items, such as initial purchase price, lead time and aesthetics, focusing more upon how each user and support groups interact with the items. The results are reflected in the following specifications, are listed in priority, and all products on the standards program have been vetted to address these expectations.

Quality

All products must last a minimum of 30 years, within the demanding environment of a community college; All products must provide maximum utilization for applications in which they are being used; Procurement costs and maintenance costs must be appropriate to the college's long term fiscal reality; Products must be able to demonstrate a clear return on investment.

Comfort & Safety

All products must provide intuitive, active comfort capabilities, appropriate to the function of the item; All products must address concerns of Universal Design without creating undue financial burden on the college; All products must demonstrate capability to proactively avoid ergonomic concerns of users; All products must inherently reduce safety issues by nature of their construction; All products must require minimal maintenance to retain a safe environment if used appropriately.

Total Cost of Ownership

All products must reduce the entire range of expenses related to installation, maintenance, replacement, utilization, human interface, procurement, and warranty requirements, both present and on-going for the expected long life of the item.

Full definitions of issues identified by the committee during the Dovetail Decision Criteria process, as well as justifications for each requirement, may be found in Appendix I.

How each vendor responded to the performance requirements may be found in Appendix II.

For those items that are not addressed by the Standards Program, the committee has developed a Performance Specification Questionnaire, created to pose specific questions to users that will define issues and programmatic needs and direct the project team toward the appropriate product recommendation. This may be found in Appendix III.

FURNITURE APPLICATION MATRIX

The following chart defines the various applications, product types, and vendor product information for the standards program as of this date.

Application	Product
Academic Environments	
Student ADA Table	KI Workup Height Adjustable, Pneumatic
Student Computer Table	KI Datalink
Student Computer Chair (5 Star)	KI Strive 5 Star Base, Armless, Poly
Student Classroom Table	KI Pirouette Flip Top, Training Base
Faculty Classroom Table	KI Workup Height Adjustable, Pneumatic
Student or Faculty Classroom Chair (4 Leg)	KI Strive 4 Leg, Armless, Poly Seat & Back
Traditional Student Desk	KI Strive 360, Poly Seat & Back
Dynamic Student Desk	KI Strive Learn2, Poly Seat & Back
Student Tablet Armchair	KI Strive w/Oversized Tablet, Flip, Poly Seat & Back
Mobile Instructor's Lectern	KI All Terrain Storage Tower, Mobile
Student Lab Stool	KI Strive Stool, Armless, Locking Casters, Poly
Faculty Lab Stools	KI Strive Stools, Arms, Poly Seat & Back
Administrative Environments	
Office Desk (all)	KI Workup Height Adjustable, Pneumatic
Office Desk (special)	KI Workup Height Adjustable, Electric
Office Storage – Faculty	KI 700 Series Locker w/Wardrobe
Office Storage – Faculty Credenza	KI Connection Zone, Full Storage
Office Storage – Adjunct Faculty	KI Connection Zone Lockers
Office, Workstation Storage – General	KI 700 Series
Staff Workstation	KI Unite Panels
Monitor Arms, Single or Dual	KI Flat Screen System
Executive Office Casegoods	KI Aristotle Series
Faculty or Student Task Seating (2 options)	KI Strive Task Chair, Arms, Uph. Seat & Back
	Herman Miller Setu, Arms, Mesh Seat & Back
Intensive Use Task Seating (2 options)	KI Impress Ultra, Adj. Arms, Mesh Back, Uph. Seat
	Herman Miller Mirra 2, Adj. Arms, Mesh Seat & Back
Faculty & Staff Office Guest Seating	KI Strive 4 Leg, Arms, Poly
Executive Office Guest Seating	KI Affina 4 Leg, Arms, Uph. Seat & Back

Application	Product
Specialty and Common Areas	
Public Area Benches (2 options)	Herman Miller Public Seating Series, Uph.
	KI Hub Series, Uph.
Meeting Room Table	Herman Miller Everywhere
Meeting Room Seating (4 Leg)	Herman Miller Caper 4 Leg, Arms, Poly Seat & Back
Meeting Room Seating (5 Star)	Herman Miller Setu 5 Star Base, Mesh Seat & Back
Meeting Room Storage	KI 700 Series
Dining or Break Room Table	Herman Miller Everywhere
Dining or Break Room Seating	KI Strive High-Density Stack, Sled, Poly Seat & Back
Lounge Seating, All Locations (2 Options)	Herman Miller Swoop Series, Uph.
	Herman Miller Public Seating Series, Uph.

**Solano College (Project Name)
Individual Selection Forms**

Typical Faculty Offices

Standard Product Included in All Offices (Per Person):

- (1) Desk: 30D" x 72W", Height Adjustable, with pencil drawer
- (1) Storage Credenza: 24"D x 66"W x 24"H, with Filing storage
- (1) 4 Leg Guest Chair: Armless, Polypropylene Seat and Back
- (1) Storage Tower with Wardrobe Unit: 36"W x 18"D x 65"H
- (1) Tall Bookcase: 36"W x 12"D x 65"H

(Note: Finishes for all offices will be the same for these items in all offices)

Product Electives (Circle Selection per Category):

1. Task Chair Option: _____

2. Wallboard Option: (4'W x 4'H): White Board **OR** Tack Board

3. Configuration Option: Layout A **OR** Layout B **OR** Layout C

NOTES:

Name: (auto-populates)

Bldg./Office #: (auto-populates)

Signature: _____ Date: _____

Design Team Consultant: _____

**Solano College (Project Name)
Individual Selection Forms**

Typical Staff Offices

Standard Product Included in All Offices (Per Person):

- (1) Desk: 30D" x 72W", Height Adjustable, with pencil drawer
- (1) Return: 24"D x 42"W, Height Adjustable, w/Mobile Ped below (B/F)
- (2) Overhead Storage Units w/Doors, Task Lights and Tack Boards
- (2) Tall Bookcases: 36"W x 12"D x 65"H
- (2) 4 Leg Guest Chairs: Armless, Polypropylene Seat and Back

(Note: Finishes for all offices will be the same for these items in all offices)

Product Electives (Circle Selection per Category):

1. Task Chair Option: _____
2. Storage Unit Configuration: All Filing **OR** Combination Filing/Binder Storage
3. Configuration Option: Layout A **OR** Layout B **OR** Layout C

NOTES:

Name: (auto-populates)

Bldg./Office #: (auto-populates)

Signature: _____ Date: _____

Design Team Consultant: _____

Solano Community College

Standards Documentation

Item: Faculty Classroom Table, Student ADA Table

Applications: Classrooms

Product Specifications:

Manufacturer: KI

Product Name: WorkUp Pneumatic Height Adjustable Table

Product Model Number: WU2448CB-74P; WU2472CB-74P

Details: Product shall be specified as 24"x48" for Student Use, 24"x72" for Instructor's Use in Classrooms, with pneumatic height adjustment, high pressure laminate top, 2mm edge, and square corners only. All finishes shall be selected based upon Campus Finish Palette options only; vendor shall include all specifications, field verifications, and CAD plans as part of their contract price; installation will be either provided under the scope of the project contractor, or through the District – confirm prior to order placement.

Product Image:



Solano Community College

Standards Documentation

Item: Student Computer Table

Applications: Classrooms

Product Specifications:

Manufacturer: KI

Product Name: Datalink Fixed Leg Powered Computer Table

Product Model Number: DX247229-74P-T6

Details: Product shall be specified as 24" x 72" for two (2) typical, with Hardwired or Single Circuit power, high pressure laminate, 2mm PVC edge, center surface mounted power unit, and square corners only. All finishes shall be selected based upon Campus Finish Palette options only; vendor shall include all specifications, field verifications, and CAD plans as part of their contract price; installation will be either provided under the scope of the project contractor, or through the District – confirm prior to order placement.

Product Image:



Solano Community College

Standards Documentation

Item: Student or Faculty Computer Chair

Applications: Computer Labs

Product Specifications:

Manufacturer: KI

Product Name: Strive Armless Chair, 5 Star Base

Product Model Number: SPDNAP

Details: Product shall be specified with 5 star base, all polypropylene seat and back, pneumatic lift, and carpet or hard floor casters as applicable. All finishes shall be selected based upon Campus Finish Palette options only; vendor shall include all specifications, field verifications, and CAD plans as part of their contract price; installation will be either provided under the scope of the project contractor, or through the District – confirm prior to order placement.

Product Image:



Solano Community College

Standards Documentation

Item: Classroom Table

Applications: Classrooms, Study Areas

Product Specifications:

Manufacturer: KI

Product Name: Pirouette Flip-top/Nesting w/Training Base

Product Model Number: PIFR2472T/74P

Details: Product shall be specified as 24”D x 72”W for two students, with high pressure laminate worksurface, fused 74 P 2 mm edges, square corners, flip-top post training base legs with 4” casters only. All finishes shall be selected based upon Campus Finish Palette options only; vendor shall include all specifications, field verifications, and CAD plans as part of their contract price; installation will be either provided under the scope of the project contractor, or through the District – confirm prior to order placement.

Product Image:



Solano Community College

Standards Documentation

Item: Student Faculty or Classroom Chair, 4 Leg

Applications: Classrooms, Study Areas

Product Specifications:

Manufacturer: KI

Product Name: Strive 4 Leg Chair, Armless

Product Model Number: SLNAP

Details: Product shall be specified with 4 legs, polypropylene seat and back, and Stainless Steel glides only. All finishes shall be selected based upon Campus Finish Palette options only; vendor shall include all specifications, field verifications, and CAD plans as part of their contract price; installation will be either provided under the scope of the project contractor, or through the District – confirm prior to order placement.

Product Image:



Solano Community College

Standards Documentation

Item: Traditional Student Desk

Applications: Classrooms, Study Areas

Product Specifications:

Manufacturer: KI

Product Name: Strive 360 Student Desk

Product Model Number: 360STP/AR/RT/30

Details: Product shall be specified with polypropylene seat and back, pneumatic adjustable seat height, automatic seat return, 20”D x 24”W high pressure laminate worksurface, and adjustable spacing in 1”increments for up to 4” of belly room. All finishes shall be selected based upon Campus Finish Palette options only; vendor shall include all specifications, field verifications, and CAD plans as part of their contract price; installation will be either provided under the scope of the project contractor, or through the District – confirm prior to order placement.

Product Image:



Solano Community College

Standards Documentation

Item: Dynamic Student Desk

Applications: Classrooms, Study Areas

Product Specifications:

Manufacturer: KI

Product Name: Strive Learn2 Student Desk

Product Model Number: L2STP/NA/FBR/LW

Details: Product shall be specified with polypropylene seat and back, 220 degree rotation of high pressure laminate work surface, lacquered clear coat edge, flat accessory rack, and roller leg terminations in carpeted rooms; 69 terminations where vinyl tile, sheet goods, or sealed concrete – provide glides on front legs and rollers on back legs. All finishes shall be selected based upon Campus Finish Palette options only; vendor shall include all specifications, field verifications, and CAD plans as part of their contract price; installation will be either provided under the scope of the project contractor, or through the District – confirm prior to order placement.

Product Image:



Solano Community College

Standards Documentation

Item: Student Tablet Armchair

Applications: Classrooms, Study Areas

Product Specifications:

Manufacturer: KI

Product Name: Strive Tablet Arm Chair w/ Oversized Tablet

Product Model Number: SLOVTAPRH, SLOVTAPLH

Details: Product shall be specified with polypropylene seat and back, 15.5" x 22.5" x 14" high pressure laminate flip-up worksurface with lacquered and sealed edges on plywood core, and Stainless Steel glides only. All finishes shall be selected based upon Campus Finish Palette options only; vendor shall include all specifications, field verifications, and CAD plans as part of their contract price; installation will be either provided under the scope of the project contractor, or through the District – confirm prior to order placement.

Product Image:



Solano Community College

Standards Documentation

Item: Mobile Instructor's Lectern

Applications: Classrooms

Product Specifications:

Manufacturer: KI

Product Name: Instruct All Terrain Binder Tower

Product Model Number: ATBT39LC-74P-S2R

Details: Product shall be specified with 4 casters, (2 locking), flat landing pad, locking door, 2 adjustable shelves, and 2 accessory slots. All finishes shall be selected based upon Campus Finish Palette options only; vendor shall include all specifications, field verifications, and CAD plans as part of their contract price; installation will be either provided under the scope of the project contractor, or through the District – confirm prior to order placement.

Product Image:



*Note: Image contains a sloped landing pad

Solano Community College

Standards Documentation

Item: Student Lab Stool

Applications: Wet or Dry Lab Environments

Product Specifications:

Manufacturer: KI

Product Name: Strive Stool, Armless

Product Model Number: SPSNAP

Details: Product shall be specified with polypropylene seat and back, pressure locking casters, pneumatic height adjustment of 22"H to 32-1/2"H, adjustable-height foot ring, and black base only. All finishes shall be selected based upon Campus Finish Palette options only; vendor shall include all specifications, field verifications, and CAD plans as part of their contract price; installation will be either provided under the scope of the project contractor, or through the District – confirm prior to order placement.

Product Image:



Solano Community College

Standards Documentation

Item: Faculty Lab Stool

Applications: Wet Lab Environments

Product Specifications:

Manufacturer: KI

Product Name: Strive Stool w/Arms

Product Model Number: SPSCAP

Details: Product shall be specified with polypropylene seat and back, pressure locking casters, pneumatic height adjustment of 22"H to 32-1/2"H, fixed cantilever arms, adjustable-height foot ring, and black base only. All finishes shall be selected based upon Campus Finish Palette options only; vendor shall include all specifications, field verifications, and CAD plans as part of their contract price; installation will be either provided under the scope of the project contractor, or through the District – confirm prior to order placement.

Product Image:



Solano Community College

Standards Documentation

Item: Faculty Lab Stool

Applications: Dry Lab Environments

Product Specifications:

Manufacturer: KI

Product Name: Strive Stool w/Arms

Product Model Number: SPSCAU

Details: Product shall be specified with polypropylene back and upholstered seat, pressure locking casters, pneumatic height adjustment of 22"H to 32-1/2"H, fixed cantilever arms, adjustable-height foot ring, and black base only. All finishes shall be selected based upon Campus Finish Palette options only; vendor shall include all specifications, field verifications, and CAD plans as part of their contract price; installation will be either provided under the scope of the project contractor, or through the District – confirm prior to order placement.

Product Image:



Solano Community College

Standards Documentation

Item: Office Desk, Height Adjustable

Applications: Faculty, Staff Offices and Workstations

Product Specifications:

Manufacturer: KI

Product Name: WorkUp Pneumatic Height Adjustable Table

Product Model Number: WU3072CB-74P

Details: Product shall be specified as 30" x 72" for primary worksurface, with pneumatic height adjustment, high pressure laminate top, 2mm edge, and square corners only. All finishes shall be selected based upon Campus Finish Palette options only; vendor shall include all specifications, field verifications, and CAD plans as part of their contract price; installation will be either provided under the scope of the project contractor, or through the District – confirm prior to order placement.

Product Image:



Solano Community College

Standards Documentation

Item: Office Desk, Special Electrical Height Adjustment

Applications: Offices as needed

Product Specifications:

Manufacturer: KI

Product Name: WorkUp Electric Height Adjustable Table

Product Model Number: WU3072HF-74P

Details: Product shall be specified only by special arrangement for medical necessity, as 30" x 72" for primary worksurface, with pneumatic height adjustment, high pressure laminate top, 2mm edge, and square corners only. All finishes shall be selected based upon Campus Finish Palette options only; vendor shall include all specifications, field verifications, and CAD plans as part of their contract price; installation will be either provided under the scope of the project contractor, or through the District – confirm prior to order placement.

Product Image:



Solano Community College

Standards Documentation

Item: Faculty Office Storage

Applications: Offices

Product Specifications:

Manufacturer: KI

Product Name: 700 Series Locker with Wardrobe

Product Model Number: 7CFL3061518/3D285C/6FLL OR
7CFL3061518/3D285C/6FLR

Details: Product shall be specified with Binder/Book Storage, wardrobe and coat rod, and 3 lateral files (file front to back), 36"W x 18"D x 66"H, 3 locks per unit; key alike to office only. Finishes shall be selected based upon Campus Finish Palette options only; vendor shall include all specifications, field verifications, and CAD plans as part of their contract price; installation will be either provided under the scope of the project contractor, or through the District – confirm prior to order placement.

Product Image:



Solano Community College

Standards Documentation

Item: Faculty Office Storage

Applications: Office

Product Specifications:

Manufacturer: KI

Product Name: Connection Zone Credenza, Full Storage

Product Model Number: CZSCL60180BFBF

Details: Product shall be specified with storage on both sides, 6”H upper box drawer, and 12”H lower lateral file drawer, locking key alike, laminate top, 60”W x 18”D x 24”H only. All finishes shall be selected based upon Campus Finish Palette options only; vendor shall include all specifications, field verifications, and CAD plans as part of their contract price; installation will be either provided under the scope of the project contractor, or through the District – confirm prior to order placement.

Product Image:



*Note: Image of unit does not reflect Full Storage configuration, which is Campus Standard

Solano Community College

Standards Documentation

Item: Adjunct Faculty Office Storage

Applications: Work Areas

Product Specifications:

Manufacturer: KI

Product Name: Connection Zone Locker

Product Model Number: TBD

Details: Product shall be specified with individually locking “2 x 2” 15” lockers, 30”W x 18”D, overall height to be determined by project, and keypad lock per unit only. Finishes shall be selected based upon Campus Finish Palette options only; vendor shall include all specifications, field verifications, and CAD plans as part of their contract price; installation will be either provided under the scope of the project contractor, or through the District – confirm prior to order placement.

Product Image:



Solano Community College

Standards Documentation

Item: Office Storage

Applications: Offices, Workstations

Product Specifications:

Manufacturer: KI

Product Name: 700 Series Lateral Files & Storage

Product Model Number: Various

Details: Product shall be specified to meet project requirements, steel construction, front to back filing in lateral file drawer shall be standard, keyed alike locks, integral file pull only. All finishes shall be selected based upon Campus Finish Palette options only; vendor shall include all specifications, field verifications, and CAD plans as part of their contract price; installation will be either provided under the scope of the project contractor, or through the District – confirm prior to order placement.

Product Image:



Solano Community College

Standards Documentation

Item: Panels

Applications: Staff Workstations

Product Specifications:

Manufacturer: KI

Product Name: Unite

Product Model Number: Various

Details: Product shall be specified with power at the worksurface level, raceway on the inside, non-elevated panels (flat to floor) fabric finish only. Frosted translucent stackers shall be available as defined by project. All finishes shall be selected based upon Campus Finish Palette options only; vendor shall include all specifications, field verifications, and CAD plans as part of their contract price; installation will be either provided under the scope of the project contractor, or through the District – confirm prior to order placement.

Product Image:



Solano Community College

Standards Documentation

Item: Monitor Arm

Applications: Faculty/Staff Work Areas, Computer Lab Applications

Product Specifications:

Manufacturer: KI

Product Name: Flat Screen System

Product Model Number: CFS05.SL

Details: Product shall be specified with 12" Post, and either single or dual arm configuration, as appropriate to the application; VESA compliant mounting brackets, and Grommet Mount connection only. All finishes shall be selected based upon Campus Finish Palate options only; vendor shall include all specifications, field verifications, and CAD plans as part of their contract price; installation will be either provided under the scope of the project contractor, or through the District – confirm prior to order placement.

Product Image:



Solano Community College

Standards Documentation

Item: Executive Office Casegoods

Applications: Executive Offices

Product Specifications:

Manufacturer: KI

Product Name: Aristotle

Product Model Number: Various

Details: Product shall be specified to meet project requirements, with details defined per overall performance specifications of college. All finishes shall be selected based upon Campus Finish Palette options only; vendor shall include all specifications, field verifications, and CAD plans as part of their contract price; installation will be either provided under the scope of the project contractor, or through the District – confirm prior to order placement.

Product Image:



Solano Community College

Standards Documentation

Item: Faculty or Student Task Seating

Applications: Offices, Workstations

Product Specifications:

Manufacturer: KI

Product Name: Strive Task Chair, 5 Star Base w/Arms

Product Model Number: SPDCAUB

Details: Product shall be specified with 5 star base, pneumatic height adjustment, cantilever arms, upholstered seat and back, and carpet or hard floor casters as applicable. All finishes shall be selected based upon Campus Finish Palette options only; vendor shall include all specifications, field verifications, and CAD plans as part of their contract price; installation will be either provided under the scope of the project contractor, or through the District – confirm prior to order placement.

Product Image:



Solano Community College

Standards Documentation

Item: Multi-Purpose Task Chair

Applications: Faculty and Student Task Seating

Product Specifications:

Manufacturer: Herman Miller

Product Name: Setu Chair

Product Model Number: CQ51MA

Details: Product shall be specified with 5-star base, standard height range, lyris suspension seat and back, ribbon arms and hard or carpet casters, as appropriate. All finishes shall be selected based upon Campus Finish Palate options only; vendor shall include all specifications, field verifications, and CAD plans as part of their contract price; installation will be either provided under the scope of the project contractor, or through the District – confirm prior to order placement.

Product Image:



Solano Community College

Standards Documentation

Item: Intensive Use Task Seating

Applications: Administration and Staff

Product Specifications:

Manufacturer: KI

Product Name: Impress Ultra Midback Task Chair

Product Model Number: KI74/JR39

Details: Product shall be specified with sliding seat pan, mesh height adjustable back, pneumatic height adjustment, free-floating mode, adjustable T-Arm, black molded urethane arm cap with 3" of height adjustment, and carpet casters only. All finishes shall be selected based upon Campus Finish Palette options only; vendor shall include all specifications, field verifications, and CAD plans as part of their contract price; installation will be either provided under the scope of the project contractor, or through the District – confirm prior to order placement.

Product Image:



Solano Community College

Standards Documentation

Item: Intensive Use Task Chair

Applications: Administrative Area Task Seating

Product Specifications:

Manufacturer: Herman Miller

Product Name: Mirra 2 Chair

Product Model Number: MRF122AWAF

Details: Product shall be specified with Chair with Standard Height cylinder, Tilt limiter, non-upholstered adjustable arms, flex adjustable seat depth, butterfly suspension back, and hard or carpet casters, as appropriate; all finishes shall be selected based upon Campus Finish Palette options only; vendor shall include all specifications, field verifications, and CAD plans as part of their contract price; installation will be either provided under the scope of the project contractor, or through the District – confirm prior to order placement.

Product Image:



Solano Community College

Standards Documentation

Item: Office Guest Seating

Applications: Offices, Workstations

Product Specifications:

Manufacturer: KI

Product Name: Strive 4 Leg Chair w/Arms

Product Model Number: SLCAP

Details: Product shall be specified with polypropylene seat and back, fixed cantilever arms, and Stainless Steel glides only. All finishes shall be selected based upon Campus Finish Palette options only; vendor shall include all specifications, field verifications, and CAD plans as part of their contract price; installation will be either provided under the scope of the project contractor, or through the District – confirm prior to order placement.

Product Image:



Solano Community College

Standards Documentation

Item: Executive Office Guest Chair

Applications: Executive Offices

Product Specifications:

Manufacturer: KI

Product Name: Affina

Product Model Number: 1901

Details: Product shall be specified with wood frame and arms, upholstered seat and back, and Stainless Steel glides only. All finishes shall be selected based upon Campus Finish Palette options only; vendor shall include all specifications, field verifications, and CAD plans as part of their contract price; installation will be either provided under the scope of the project contractor, or through the District – confirm prior to order placement.

Product Image:



Solano Community College

Standards Documentation

Item: Benches

Applications: Public Areas

Product Specifications:

Manufacturer: Herman Miller

Product Name: Public Office Landscape

Product Model Number: Varies

Details: Product shall be specified to accommodate the requirements of the project. Glides are to be appropriate to flooring condition, and shall not mar surface. All finishes shall be selected based upon Campus Finish Palate options only; vendor shall include all specifications, field verifications, and CAD plans as part of their contract price; installation will be either provided under the scope of the project contractor, or through the District – confirm prior to order placement.

Product Image:

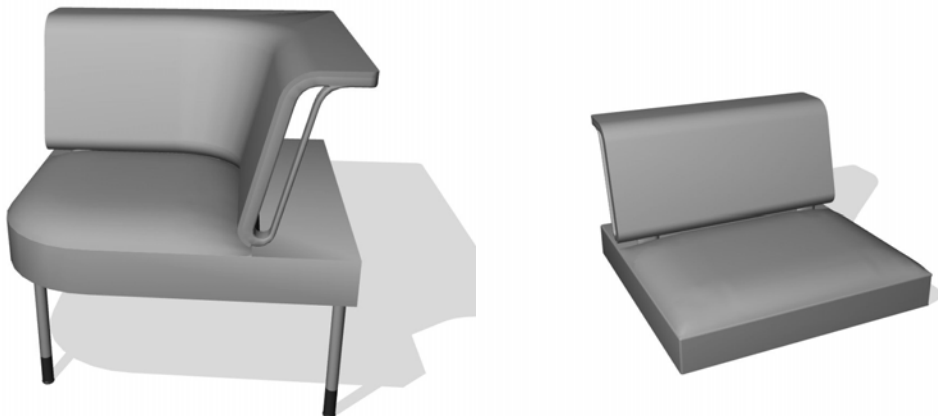

Solano Community College

Standards Documentation

Item: Benches

Applications: Public Areas

Product Specifications:

Manufacturer: KI

Product Name: Hub Series

Product Model Number: Varies

Details: Product shall be specified with or without back, in sizes appropriate to project requirements, sled base with appropriate glides for flooring only. All finishes shall be selected based upon Campus Finish Palette options only; vendor shall include all specifications, field verifications, and CAD plans as part of their contract price; installation will be either provided under the scope of the project contractor, or through the District – confirm prior to order placement.

Product Image:



Solano Community College

Standards Documentation

Item: Meeting Table

Applications: Meeting Rooms

Product Specifications:

Manufacturer: Herman Miller

Product Name: Everywhere Table

Product Model Number: DT1AS.XXXL (Sizes Vary)

Details: Product shall be specified as rectangular table, squared edge, high-pressure laminate surface, and post leg, with glides unless casters are required by project application; All finishes shall be selected based upon Campus Finish Palate options only; vendor shall include all specifications, field verifications, and CAD plans as part of their contract price; installation will be either provided under the scope of the project contractor, or through the District – confirm prior to order placement.

Product Image:



Solano Community College

Standards Documentation

Item: 4 Leg Chair

Applications: Meeting Rooms

Product Specifications:

Manufacturer: Herman Miller

Product Name: Caper Chair

Product Model Number: WC410N

Details: Product shall be specified with polypropylene seat and back, no arms, and carpet glides only. All finishes shall be selected based upon Campus Finish Palate options only; vendor shall include all specifications, field verifications, and CAD plans as part of their contract price; installation will be either provided under the scope of the project contractor, or through the District – confirm prior to order placement.

Product Image:



Solano Community College

Standards Documentation

Item: Meeting Room Chair

Applications: Meeting Rooms

Product Specifications:

Manufacturer: Herman Miller

Product Name: Setu Chair

Product Model Number: CQ51MA

Details: Product shall be specified with 5-star base, standard height range, lyris suspension seat and back, ribbon arms and hard or carpet casters, as appropriate. All finishes shall be selected based upon Campus Finish Palate options only; vendor shall include all specifications, field verifications, and CAD plans as part of their contract price; installation will be either provided under the scope of the project contractor, or through the District – confirm prior to order placement.

Product Image:



Solano Community College

Standards Documentation

Item: Storage Units

Applications: Meeting Rooms

Product Specifications:

Manufacturer: KI

Product Name: 700 Series Storage

Product Model Number: Various

Details: Product shall be specified to meet project requirements, steel construction, front to back filing in lateral file drawer shall be standard, keyed alike locks, integral file pull and continuous laminate top only. All finishes shall be selected based upon Campus Finish Palette options only; vendor shall include all specifications, field verifications, and CAD plans as part of their contract price; installation will be either provided under the scope of the project contractor, or through the District – confirm prior to order placement.

Product Image:

Solano Community College

Standards Documentation

Item: Fixed Height Table

Applications: Dining, Break Rooms

Product Specifications:

Manufacturer: Herman Miller

Product Name: Everywhere Table

Product Model Number: DT1AS.XXXL (Sizes Vary)

Details: Product shall be specified as size appropriate to project requirements, squared edge, high-pressure laminate surface, and post leg, with glides only; All finishes shall be selected based upon Campus Finish Palate options only; vendor shall include all specifications, field verifications, and CAD plans as part of their contract price; installation will be either provided under the scope of the project contractor, or through the District – confirm prior to order placement.

Product Image:



Solano Community College

Standards Documentation

Item: Seating

Applications: Dining, Break Room

Product Specifications:

Manufacturer: KI

Product Name: Strive High Density Stack Chair, Sled Base

Product Model Number: SWNA

Details: Product shall be specified with molded polypropylene seat and back, chrome wire frame, and stainless steel glides only. All finishes shall be selected based upon Campus Finish Palette options only; vendor shall include all specifications, field verifications, and CAD plans as part of their contract price; installation will be either provided under the scope of the project contractor, or through the District – confirm prior to order placement.

Product Image:



Solano Community College

Standards Documentation

Item: Student or Staff Area Lounge Seating

Applications: Lounge/Break Area seating

Product Specifications:

Manufacturer: Herman Miller

Product Name: Swoop

Product Model Number: Varies

Details: Product shall be specified to accommodate the requirements of the project. Glides are to be appropriate to flooring condition, and shall not mar surface. All finishes shall be selected based upon Campus Finish Palate options only; vendor shall include all specifications, field verifications, and CAD plans as part of their contract price; installation will be either provided under the scope of the project contractor, or through the District – confirm prior to order placement.

Product Images:

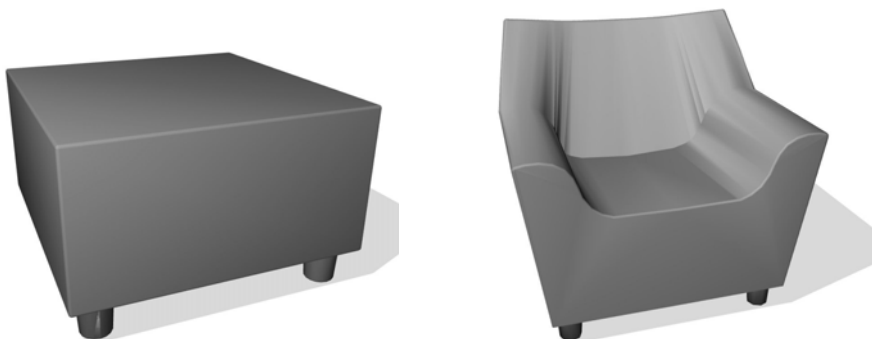

Solano Community College

Standards Documentation

Item: Staff or Student Area Lounge Seating

Applications: Lounge/Break Areas

Product Specifications:

Manufacturer: Herman Miller

Product Name: Public Office Landscape

Product Model Number: Varies

Details: Product shall be specified to accommodate the requirements of the project. Glides are to be appropriate to flooring condition, and shall not mar surface. All finishes shall be selected based upon Campus Finish Palate options only; vendor shall include all specifications, field verifications, and CAD plans as part of their contract price; installation will be either provided under the scope of the project contractor, or through the District – confirm prior to order placement.

Product Image:

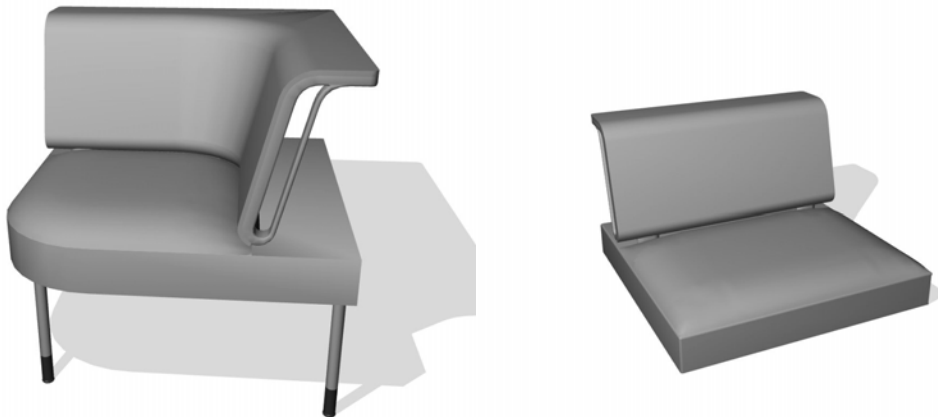

**DOCUMENT CONTROL RECORD
SOLANO FURNITURE STANDARDS PROGRAM**

REVISION NUMBER	BY	DATE	KEY CHANGES
Original	FF&E Committee	5/26/15	
1	Board of Trustees	2/21/18	
2			
3			
4			
5			
6			
7			
8			
9			
10			
11			
12			
13			
14			
15			
16			
17			
18			
19			
20			

**APPENDIX I:
SOLANO COLLEGE
FF&E PERFORMANCE SPECIFICATIONS
PRIORITIZED**

Criterion	Committee Definition	Issues This Would Solve
#1: Quality	All products must last a minimum of 30 years, within the demanding environment of a community college; All products must provide maximum utilization for applications in which they are being used; Procurement costs and maintenance costs must be appropriate to the college's long term fiscal reality; Products must be able to demonstrate a clear return on investment.	Extends the life of more products, reducing general fund output; Insures that taxpayers are getting the best value; Wouldn't have to go through this process as often; High quality items so don't need a replacement strategy as soon.
#2: Comfort & Safety	All products must provide intuitive, active comfort capabilities, appropriate to the function of the item; All products must address concerns of Universal Design without creating undue financial burden on the college; All products must demonstrate capability to proactively avoid ergonomic concerns of users; All products must inherently reduce safety issues by nature of their construction; All products must require minimal maintenance to retain a safe environment if used appropriately.	Comfort has been too focused on the short term; Demographics are changing and expanding; There are changing expectations as to what "comfort" means and can be very subjective; Options to get more comfortable have not been intuitive enough; Not had a proactive focus; There haven't been enough choices from which to select; Not enough focus on Universal Design; Avoids workers compensation claims; Products aren't maintained to perform well over time; Products purchased by individual users have created many safety issues.
#3: Total Cost of Ownership (TCO)	Products must reduce the entire range of expenses related to installation, maintenance, replacement, utilization, human interface, procurement, and warranty requirements, both present and on-going for the expected long life of the item.	Inadequate budgeting, resulting in antiquated equipment and marginal maintenance support; Avoids expensive surprises by anticipating all costs throughout the life of the product.

APPENDIX II
 SOLANO COLLEGE DISTRICT
 FURNITURE STANDARDS PROCESS
 VENDOR RESPONSE FORM #1

21 February 2018

APPLICATION:	VENDOR PRODUCT RECOMMENDATION:	QUALITY	COMFORT & SAFETY	TOTAL COST OF OWNERSHIP
ACADEMIC				
Student ADA Table	Renew Electric Height Adj	Meets and surpasses ANSI/BIFMA tests for height adjustable products. Up to 74% recyclable.	Eased edge gives support forearms and soften sharp edges. Soft angles under table to protect knees from bumps/bruises.	12 Year Warranty: Worksurface. Electric motor uses less power than cell phone charger.
Student Computer Table	Everywhere	Meets and surpasses ANSI/BIFMA X5.5. 200lb load weight capacity.	Eased edge gives support forearms and soften sharp edges. Casters available for simple movement.	Product has a 12 year, 3 shift warranty including parts and labor.
Student or Faculty Computer Chair (5 Star)	Caper Multipurpose Chair	Meets and surpasses ANSI/BIFMA X5.1-1993. Rated to 300lb weight capacity.	Molded polypropylene seat and back contoured for comfort along with air venting.	Product has a 12 year, 3 shift warranty including parts and labor.
Student or Faculty Classroom Table	Everywhere	Meets and surpasses ANSI/BIFMA X5.5. 200lb load weight capacity.	Eased edge gives support forearms and soften sharp edges. Casters available for simple movement.	Product has a 12 year, 3 shift warranty including parts and labor.
Student or Faculty Classroom Chair (4 Leg)	Caper	Meets and surpasses ANSI/BIFMA X5.1-1993. Rated to 300lb weight capacity.	Molded polypropylene seat and back contoured for comfort along with air venting.	Product has a 12 year, 3 shift warranty including parts and labor.
Traditional Student Desk	Everywhere	Meets & Surpasses ANSI BIFMA X5.5-1998. 200lb load weight capacity.	Eased edge gives support forearms and soften sharp edges. Casters available for simple movement.	Product has a 12 year, 3 shift warranty including parts and labor.
Dynamic Student Desk	Renew Electric Height Adj	Meets and surpasses ANSI/BIFMA X5.5 tests for height adjustable products. Up to 74% recyclable.	Eased edge gives support forearms and soften sharp edges. Soft angles under table to protect knees from bumps/bruises.	12 Year Warranty: Worksurface. Electric motor uses less power than cell phone charger.
Student Tablet Armchair	Caper w/Tablet	Meets and surpasses ANSI/BIFMA X5.1-1993. Rated to 300lb weight capacity.	Molded polypropylene seat and back contoured for comfort along with air venting.	Product has a 12 year, 3 shift warranty including parts and labor.
AV Storage Unit	N/A	N/A	N/A	N/A

SOLANO COLLEGE DISTRICT
 FURNITURE STANDARDS PROCESS
 VENDOR RESPONSE FORM #1

21 February 2018

APPLICATION:	VENDOR PRODUCT RECOMMENDATION:	QUALITY	COMFORT & SAFETY	TOTAL COST OF OWNERSHIP
Instructor's Stool (Wet Environment)	Equa Stool or Caper Stool	Equa 2: Meets and surpasses BIFMA X5.1-2011. Rated to 300lb weight capacity. CAL133 certified. GREENGUARD Gold Certified.	Equa 2's unique H-shaped design provides the functionality to deliver comfort to diverse range of seated positions with the benefit of no complicated adjustments. Additionally, Equa 2 also provides users with 3 size options in order to accommodate the broadest range of people, providing a memorable combination of fit and ergonomics.	Product has a 12 year, 3 shift warranty including parts and labor. 5 yr. fabric
Instructor's Stool (Dry Environment)	Setu Stool or Caper Stool	Setu stool meets ANSI/BIFMA X55.1-1993 Rated to 300 weight	1piece Lyrus suspension for comfort. Base is anti-corrosive Aluminum. Swivel 360 and Pneumatic Height	Product has a 12 year, 3 shift warranty including parts and labor. 5 yr. fabric
Student Lab Stool (Wet or Dry Environment)	Caper Stool	Meets & surpasses ANSI/BIFMA 5.1-1993. rated to 300 LBS	Stool w/molded polypropylene seat and back contoured for comfort along with air venting. Glides. Pneumatic option available.	Product has a 12 year, 3 shift warranty including parts and labor.
ADMINISTRATIVE				
Office Desk, Fixed Height (all)	Canvas	Meets or surpasses ANSI/BIFMA X5.9-2004	Simple set of elements with various sizes, edges and shapes. 45 LB. density core with laminate or wood. 1 1/8" thick.	Product has a 12 year, 3 shift warranty including parts and labor.
Office Desk, Adjustable Height (all)	Renew Electric Height Adj	Meets and surpasses ANSI/BIFMA tests for height adjustable products. Up to 74% recyclable.	Eased edge gives support forearms and soften sharp edges. Soft angles under table to protect knees from bumps/bruises.	12 Year Warranty: Worksurface. Electric motor uses less power than cell phone charger

SOLANO COLLEGE DISTRICT
 FURNITURE STANDARDS PROCESS
 VENDOR RESPONSE FORM #1

21 February 2018

APPLICATION:	VENDOR PRODUCT RECOMMENDATION:	QUALITY	COMFORT & SAFETY	TOTAL COST OF OWNERSHIP
Office Overhead Cabinet (all)	Canvas	Meets and surpasses ANSI/BIFMA X5.6-2010	Attach to wall in various widths. Multiple door options and laminate or wood.	Product has a 12 year, 3 shift warranty including parts and labor.
Office Tackboards (Systems Product)	Canvas	Meets and surpasses ANSI/BIFMA X.5.6-2010 Levels and Greengard certified	3/4" thick 3 ply board covered with fabric. Various width and heights	Product has a 12 year, 3 shift warranty including parts and labor.
Office Overhead Shelf (all)	Canvas	Meets and surpasses ANSI/BIFMA X5.6-2010	Attach to wall in various widths. Multiple options for size. Laminate or wood available.	Product has a 12 year, 3 shift warranty including parts and labor.
Staff Workstation	Canvas	Meets or surpasses ANSI/BIFMA X5.9-2004 Levels and Greengard certified	Simple set of element with various sizes, edge details and shapes. 45 LB. density core with laminate or wood. 1 1/8 " thick.	Product has a 12 year, 3 shift warranty including parts and labor.
Filing/Storage Component	Tu Storage	Tu Meets ANSI/BIFMA X.5.9 and is Greengard Certified	1 piece construction. 22 Gauge steel, full extension glides w/ steel ball bearings. Lock plug	Product has a 12 year, 3 shift warranty including parts and labor.
Short Term Task Seating (2 options)	Sayl/Setu	Sayl meets ANSI/BIFMA X5.1-2011 & Setu2meets ANSI/BIFMA X5.1-2002	Sayl has 3D frameless suspension back that allows freedom of movement, Pneumatic Ht. Upholstered seat, foam padding, adjust. Arms.	Product has a 12 year, 3 shift warranty including parts and labor. 5yr fabric
Long Term Task Seating (2 options)	Sayl/Mirra 2	Sayl meets ANSI/Biffa X5.1-2011 & Mirra2meets ANSI/BIFMA X5.1-2011	Sayl-Same as above description. Mirra 2-seat material light weight-breathable distributes weight evenly. Back has fabric layer w/ flexible polymer shell. Tilt pivots at anke, knee, hip.	Product has a 12 year, 3 shift warranty including parts and labor. 5yr fabric

SOLANO COLLEGE DISTRICT
 FURNITURE STANDARDS PROCESS
 VENDOR RESPONSE FORM #1

21 February 2018

APPLICATION:	VENDOR PRODUCT RECOMMENDATION:	QUALITY	COMFORT & SAFETY	TOTAL COST OF OWNERSHIP
Office Guest Seating	Caper	Meets and surpasses ANSI/BIFMA X5.1-1993. Rated to 300lb weight capacity.	Molded polypropylene seat and back contoured for comfort along with air venting. Glides or caster options	Product has a 12 year, 3 shift warranty including parts and labor.
Staff Reception/Lounge Seating (3 Options)	Swoop Celeste Seating Public Lounge	Swoop meets ANSI/BIFMA X5.1-2011 & Lounge2meets ANSI/BIFMA X5.1-2002	Tubular frame, upholstered foam back and seat for comfort. Tablet arm 360 swivel, 2 casters in front. Public 29x29x29" social chair w/built in ergo support	Product has a 12 year, 3 shift warranty including parts and labor.
SPECIALTY AND COMMON AREAS				
Meeting Room Table	Everywhere	Meets and surpasses ANSI/BIFMA X5.5. 200lb load weight capacity.	Eased edge gives support forearms and soften sharp edges. Casters available for simple movement.	Product has a 12 year, 3 shift warranty including parts and labor.
Meeting Room Seating	Setu	meets ANSI/BIFMA X5.1-1993 300 Lb. capacity	1piece Lyrus suspension for comfort. Base is anti-corrosive Aluminum. Swivel 360 and Pneumatic Height	Product has a 12 year, 3 shift warranty including parts and labor.
Dining or Break Room Table	Everywhere	Meets and surpasses ANSI/BIFMA X5.5. 200lb load weight capacity.	Eased edge gives support forearms and soften sharp edges. Casters available for simple movement.	Product has a 12 year, 3 shift warranty including parts and labor.
Dining or Break Room Seating	Caper	Meets and surpasses ANSI/BIFMA X5.1-1993. Rated to 300lb weight capacity.	Molded polypropylene seat and back contoured for comfort along with air venting.	Product has a 12 year, 3 shift warranty including parts and labor.
Student Lounge Seating	Swoop	Meets or surpasses ANSI/BIFMA X5.1-1993	Fully upholstered foam body covering concealed plywood frame. With or without arms	Product has a 12 year, 3 shift warranty including parts and labor.

APPENDIX II
 SOLANO COLLEGE DISTRICT
 FURNITURE STANDARDS PROCESS
 VENDOR RESPONSE FORM #3

21 February 2018

APPLICATION:	VENDOR PRODUCT RECOMMEDATION	QUALITY	COMFORT & SAFETY	TOTAL COST OF OWNERSHIP
ACADEMIC				
Student ADA Table	Genesis Height Adjustable	Meets ANSI-HFS100 standard. Each model has high gauge steel components from 11-16 gauge .	Available in fixed, pin height, crank and electrical options according to user needs	On FCCC Contract, 15 year warranty, service and parts.
Student Computer Table	Datalink	Exceeds BIFMA standards for tables ensuring a long lasting product	Power up options on surface, lightweight top, foldable for storage, wireways in leg and trough system, gangable, plug and play. No loose parts	LIFETIME WARRANTY (On FCCC Contract, 15 year warranty on service.)
Student or Faculty Computer Chair (5 Star)	Strive Seating	Superseded 1,000,000 flexes or 8x BIFMA Testing, exceeded all other testing; load up to 300#	Intuitive flex poly back, part of a family of chairs for cohesive look. Arms/no arms, upholstered or poly, adjustable height. High level of comfort	On FCCC Contract, 15 year warranty, service and parts.
Student or Faculty Classroom Table	Pirouette	10" steel tubing on table base. Fixed or flip top. Standard or ADA height.	One handed flip for ease and safety, articulating leg nests inline to save space, leg placement at outer edges allowing >legroom, 18" depth available	On FCCC Contract, 15 year warranty, service and parts.
Student or Faculty Classroom Chair (4 Leg)	Strive	Superseded 1,000,000 flexes or 8x BIFMA Testing, exceeded all other testing; 300# capacity- Injection molded polypropylene with integral steel cantilever springs. No external parts	Intuitive flex poly back, part of a family of chairs for cohesive look. Arms/no arms, upholstered or poly, stacks. High level of comfort.	On FCCC Contract, 15 year warranty, service and parts.

SOLANO COLLEGE DISTRICT
 FURNITURE STANDARDS PROCESS
 VENDOR RESPONSE FORM #3

21 February 2018

APPLICATION:	VENDOR PRODUCT RECOMMEDATION	QUALITY	COMFORT & SAFETY	TOTAL COST OF OWNERSHIP
Traditional Student Desk	360 Series Desk	Pneumatic cylinder seat height adjustment. Sliding seat pan option available. Welded steel frame.	Rollers allow desks to be moved easily when unoccupied. Sliding top for additional belly room. Double entry desk with Strive Shell for comfort and durability	On FCCC Contract, 15 year warranty, service and parts.
Dynamic Student Desk	Learn2- Strive Seat	Structural chair base has a 15 year warranty standard along with a Strive Seat	Mobile, flexible, Non-handed tablet arm chair for easy collaboration. Tablet slides 6" for extra belly room. The support tube rotates around the chair seat a total of 220°, users can put off to either side or behind and easily x their legs. 280 square inches of writing surface. Bookrack /cup holder option, upholstered or poly. Bell glides, casters or combination.	On FCCC Contract, 15 year warranty, service and parts.
Student Tablet Armchair	Strive with Oversized Tablet	Superseded 1,000,000 flexes or 8x BIFMA Testing, exceeded all other testing; 300# capacity- Injection molded polypropylene with integral steel cantilever springs.	Intuitive flex poly back, part of a family of chairs for cohesive look. Arms/no arms, upholstered or poly, oversized tablet for larger workspace	On FCCC Contract, 15 year warranty, service and parts.

SOLANO COLLEGE DISTRICT
 FURNITURE STANDARDS PROCESS
 VENDOR RESPONSE FORM #3

21 February 2018

APPLICATION:	VENDOR PRODUCT RECOMMENDATION	QUALITY	COMFORT & SAFETY	TOTAL COST OF OWNERSHIP
AV Storage Unit	All Terrain	Shell is 18-gauge cold rolled steel w/ 3/4" flanges on all 4 sides. Front face has an additional flange formed inward to provide additional strength. 2 top 20-gauge reinforcements are welded in along each side of the top. Wrapper is formed 20-gauge C.R.S, and is formed with 3 /4" flanges along the 2 vertical sides. An additional flange is formed in for additional strength and accepts the interior side panels.	Mobile storage with a variety of configurable options for drawers, shelving, and a podium	LIFETIME WARRANTY (On FCCC Contract, 15 year warranty on service)
Instructor's Stool (Wet Environment)	Strive	Superseded 1,000,000 flexes or 8x BIFMA Testing, exceeded all other testing; 300# capacity- Injection molded polypropylene with integral steel cantilever springs. No external parts	Foot ring and adjustable height offering comfort with an integral flex back. Easily cleanable, very durable. Pneumatic cylinder	On FCCC Contract, 15 year warranty, service and parts.
Instructor's Stool (Dry Environment)	Strive Upholstered	Superseded 1,000,000 flexes or 8x BIFMA Testing, exceeded all other testing; 300# capacity- Injection molded polypropylene with integral steel cantilever springs. No external parts	Foot ring and adjustable height offering comfort with an integral flex back. Easily cleanable, very durable. Pneumatic cylinder	On FCCC Contract, 15 year warranty, service and parts.

SOLANO COLLEGE DISTRICT
 FURNITURE STANDARDS PROCESS
 VENDOR RESPONSE FORM #3

21 February 2018

APPLICATION:	VENDOR PRODUCT RECOMMENDATION	QUALITY	COMFORT & SAFETY	TOTAL COST OF OWNERSHIP
Student Lab Stool (Wet or Dry Environment)	Strive	Superseded 1,000,000 flexes or 8x BIFMA Testing, exceeded all other testing; 300# capacity- Injection molded polypropylene with integral steel cantilever springs. No external parts	Foot ring and adjustable height offering comfort with an integral flex back. Easily cleanable, very durable. Pneumatic cylinder	On FCCC Contract, 15 year warranty, service and parts.
ADMINISTRATIVE				
Office Desk, Fixed Height (all)	700 Series	Formed of 18 & 20 Gauge steel and double reinforced	Wide array of configurations and options to accommodate any work environment	LIFETIME WARRANTY (On FCCC Contract, 15 year warranty on service)
Office Desk, Adjustable Height (all)	Genesis Crank Height Adjustable	- meets ANSI-HFS100 standard. Each model has high gauge steel components from 11-16 gauge .	Available in fixed, pin height, crank and electrical options according to user needs	On FCCC Contract, 15 year warranty, service and parts.
Office Overhead Cabinet (all)	Universal	Self supporting or wall mounted available. 18 gauge steel shell.	Painted, laminate or fabric door. Locking storage.	LIFETIME WARRANTY (On FCCC Contract, 15 year warranty on service)
Office Tackboards (Systems Product)	Workzone	3/4" industrial insulation board covered in requested fabric	Steel mounting brackets hold tackboard in place. Field replaceable.	On FCCC Contract, 15 year warranty, service and parts.
Office Overhead Shelf (all)	Universal	Self supporting or wall mounted available. 18 gauge steel shell.	Powdercoat paint standard. Shelf dividers available.	LIFETIME WARRANTY (On FCCC Contract, 15 year warranty on service)
Staff Workstation	Unite	Top and bottom horizontal rails and vertical posts are formed of 16 gauge steel. Durable high-pressure laminate worksurfaces	Flexible, adaptable, clean design, versatile with storage products and running power. Surface power available for user access. Stackable partitions for privacy.	LIFETIME WARRANTY (On FCCC Contract, 15 year warranty on service)

SOLANO COLLEGE DISTRICT
 FURNITURE STANDARDS PROCESS
 VENDOR RESPONSE FORM #3

21 February 2018

APPLICATION:	VENDOR PRODUCT RECOMMEDATION	QUALITY	COMFORT & SAFETY	TOTAL COST OF OWNERSHIP
Filing/Storage Component	700 Series	Formed of 18 & 20 Gauge steel and double reinforced	Wide array of configurations and options to accommodate any work environment	LIFETIME WARRANTY (On FCCC Contract, 15 year warranty on service)
Short Term Task Seating (2 options)	Strive & Torsion	See Strive Task above. Torsion - a campus standard, supports 300#, exceeds BIFMA standards	See Strive previous. Torsion provides an articulating flexible back and adjustable height option in poly or upholstered for unmatched comfort.	On FCCC Contract, 15 year warranty, service and parts.
Long Term Task Seating (2 options)	Impress Ultra (mesh back) & Impress (fabric back)	3 seat height range options standard. Double spring loaded seat slide. ***Campus Standard Now***	3" Back height adjustment. Saddle shape seat. Ergonomic armrest adjustments. Easy to operate.	On FCCC Contract, 15 year warranty, service and parts.
Office Guest Seating	Versa	Versa Conference supports 300# and the Versa line exceeds BIFMA standards; 9 ply hard maple ensures back strength; 13 gauge steel with multiple welds. Kickback leg adds additional support	2 styles in a neutral design (rounded or square) back offering versatility and comfort. Stacking bumper, arms or armless. Waterfall edge and larger versions (XL) available including wall saver.	On FCCC Contract, 15 year warranty, service and parts.
Staff Reception/Lounge Seating (3 Options)	Sela, Cody, Hub	3/4" laminated hardwood construction. Sled base 16 gauge steel tubing. Seat constructed w/stretch strap webbing for strength.	Seat/back foam contour cut for consistency & comfort. Gangable for planned arrangements. Current campus product!	On FCCC Contract, 15 year warranty, service and parts.
SPECIALTY AND COMMON AREAS				
Meeting Room Table	Portico	14 gauge elliptical steel tubing. Silver brazed tube joints.	Multiple sizes & configurations. Fixed, folding, flip top options. Multiple heights available standard. Optional power and cord management.	On FCCC Contract, 15 year warranty, service and parts.

SOLANO COLLEGE DISTRICT
 FURNITURE STANDARDS PROCESS
 VENDOR RESPONSE FORM #3

21 February 2018

APPLICATION:	VENDOR PRODUCT RECOMMEDATION	QUALITY	COMFORT & SAFETY	TOTAL COST OF OWNERSHIP
Meeting Room Seating	Altus Conference	Swivel tilt mechanism is made of a stamped steel housing.		On FCCC Contract, 15 year warranty, service and parts.
Dining or Break Room Table	Portico	14 gauge elliptical steel tubing. Silver brazed tube joints.	Multiple sizes & configurations. Multiple heights available standard. Easy clean high pressure laminate w/multiple edge treatments.	On FCCC Contract, 15 year warranty, service and parts.
Dining or Break Room Seating	Strive	Injection molded polypropylene w/integral steel cantilever springs. 13 gauge tubular steel frame. Welded joints	Easy clean poly OR fabric upholstered seat/back cushions available.	On FCCC Contract, 15 year warranty, service and parts.
Student Lounge Seating	Hub	3/4" laminated hardwood construction. Sled base 16 gauge steel tubing. Seat constructed w/stretch strap webbing for strength.	Seat/back foam contour cut for consistency & comfort. Gangable for planned arrangements.	On FCCC Contract, 15 year warranty, service and parts.

APPENDIX III

PERFORMANCE SPECIFICATION FORM

Please provide responses to each of these questions relative to your project specific Equipment Requirements. If you require any assistance in this process, please contact us!

1. What item are you describing?
2. In which room will this item be located in the new facility?
3. Who uses this item ***the most*** (faculty, staff, students)?
4. When was this item ***last purchased*** for the program?
5. How old is the current item that we are replacing (if applicable)?
6. Describe the biggest problem that you have experienced in the past with the current piece of equipment:
7. How has that problem impacted the users the most (downtime, labor, etc.)?
8. What other problems have arisen relative to this item?
9. What features of the current item don't work well for the program?
10. What features are critical to have on the new item?
11. Any other details which are also important on this item?
12. Are we planning to match any existing items within the program with this new purchase?
If so, please describe:
13. What other departments need to interface with this item over its lifetime (Custodial, IT, Administration, etc.)?
14. Have you located a specific item which provides the Features and Benefits that you have identified above? If so, please provide manufacturer, model number and estimated cost for the item:
15. Any other information that you care to provide?

Thank you for your time and participation in this process. You may be asked to provide more information or confirm the purchase of the listed item.



**FOUNDATION FOR CALIFORNIA COMMUNITY COLLEGES
ADMINISTRATIVE SERVICES AGREEMENT**

CB 13-013

This ADMINISTRATION SERVICES AGREEMENT (“Agreement”) is made this **1st** day of **OCTOBER, 2013**, between the Foundation for California Community Colleges (“Foundation”) and **KRUEGER INTERNATIONAL (KI)** (“Supplier”).

RECITALS

The Foundation desires to have **KRUEGER INTERNATIONAL (KI)** (“Supplier”) provide (Services/Products) as described in RFP #13-002, which in its entirety shall serve as **Exhibit D**.

This Agreement provides that any or all public agencies, public and private school districts, public and private colleges or universities in California, or the Foundation (collectively, "Participating Public or Private Agencies") may purchase Products at prices stated in the RFP #13-002;

THEREFORE, in consideration of the payments to be made hereunder and the mutual covenants contained in this Agreement, the Foundation and Supplier hereby agree as follows:

TERMS AND CONDITIONS

1. The Supplier shall perform all of its duties, responsibilities, and obligations in the time and manner as required to be performed by the Supplier as set forth in this Agreement.
2. The Foundation shall perform all of its duties, responsibilities, and obligations as administrator of purchases under this Agreement as set forth herein, and the Supplier hereby agrees that the Foundation shall act in the capacity of administrator of purchases under this Agreement.
3. With respect to any purchases by Participating Public or Private Agencies pursuant to this Agreement, the Foundation: (i) shall not be construed as a dealer, re-marketer, representative, partner, or agent of any type of the Supplier or such Participating Public or Private Agencies; (ii) shall not be obligated, liable or responsible for any order made

by Participating Public or Private Agencies or any employee thereof under this Agreement, or for any payment required to be made with respect to such order; and (iii) shall not be obliged, liable, or responsible for any failure by any Participating Public or Private Agencies to comply with procedures or requirements of applicable law or to obtain the due authorization and approval necessary to purchase under this Agreement. The Foundation makes no representation or guaranty with respect to any minimum purchases by any Participating Public or Private Agencies or any employee thereof under this Agreement.

4. Regarding Supplier's use of Subcontractors: within ten (10) days of the issuance of a Purchase Order or other instrument evidencing the procurement of Furniture and Fixtures under this Agreement, the Supplier shall provide the Participating Public or Private Agency issuing such Purchase Order or other instrument with a written list of Subcontractor(s) to the Supplier for completing the Supplier's obligations under such Purchase Order. The written list of Subcontractors shall identify each Subcontractor who will provide work, labor, or materials valued at one-half of one percent (0.05%) of the total value of the Purchase Order and shall identify the work to be performed by each such Subcontractor and each Subcontractor's business location. The Supplier shall not substitute any listed Subcontractor, except upon the express consent of the Participating Public or Private Agency, as applicable and in strict conformity with applicable law.
5. Insurance. Within ten (10) days of the issuance of a Purchase Order or other similar instrument for the procurement of Furniture and Fixtures under this Agreement, the Supplier and each Subcontractor, identified in its Subcontractors List issued by the Supplier for such Purchase Order, shall deliver to the Foundation, and to the Participating Public or Private Agency issuing the Purchase Order or other similar instrument, Certificates of Insurance evidencing the insurance coverage in the minimum coverage amounts noted below. The foregoing notwithstanding, a Participating Public or Private Agency may require additional or different insurance coverage or minimum coverage amounts in connection with any specific procurement of Furniture and Fixtures. In such event, such additional or different insurance requirements shall be noted in the Purchase Order or other instrument evidencing the procurement of Furniture and Fixtures, and the Supplier shall comply with the same.
 - a. Workers' Compensation Insurance. The Supplier and all Subcontractors shall obtain and maintain Workers' Compensation Insurance with coverage amounts under such policies in accordance with applicable law.
 - b. Commercial General Liability Insurance. The Supplier and all Subcontractors to the Supplier shall obtain and maintain Commercial General Liability Insurance Policies covering: injuries, including accidental death, to persons; damage to property; completed operations; and contractual liability. Minimum coverage amounts under each such Commercial General Liability insurance policy shall be One Million Dollars (\$1,000,000) per occurrence and Two Million Dollars (\$2,000,000) in the aggregate.
 - c. Professional Liability Insurance. The Supplier and all Subcontractors to the Supplier shall obtain and maintain Professional Liability Insurance policies covering liability arising from any error, omission, negligent or wrongful act

of the Supplier or Subcontractor with limits of not less than \$1 million per occurrence and \$2 million aggregate.

- d. Modifications; Cancellation; Additional Insured. The Foundation and each Participating Public or Private Agency procuring Flooring Materials hereunder shall be named additional insured to the Commercial General Liability insurance policies of the Supplier and its Subcontractors for each specific procurement of Furniture and Fixtures. The Workers' Compensation insurance policy, the General Liability insurance policy, and the Professional Liability insurance policy of the Supplier and each Subcontractor for each specific procurement of Furniture and Fixtures shall include provisions that the policy terms will not be materially modified and that the policy will not be cancelled or terminated without at least thirty (30) days advance written notice to the Participating Public or Private Agency, as applicable.
6. Performance Bond. The Supplier shall, if required by the terms of the Purchase Order or other similar instrument, provide the Participating Public or Private Agency with a Performance Bond in connection with a specific procurement of Furniture and Fixtures. If required, the Performance Bond shall be in the form and content included in the RFP and shall be in a penal sum equal to One Hundred Percent (100%) of the value of such Purchase Order or other instrument. Performance Bonds, if required, shall be acceptable only if issued by an Admitted Surety Insurer under California law.

SPECIFIC PROVISIONS

7. Term. The Term of this Agreement will be for three (3) years, commencing on the date set forth in the Agreement and terminating three (3) years thereafter. The Foundation and Supplier, upon mutual consent, shall have the option to extend the Term for two (2) additional one (1) year Terms ("the Extended Terms") by written notice not less than one (1) month prior to and not more than three (3) months prior to expiration of the Term or the Extended Term, as applicable. If the option for the Extended Terms are exercised, all terms and conditions set forth herein shall be applicable to the Extended Terms, except as expressly modified by written modifications duly executed on behalf of the Foundation and the Supplier. In the event that any of, or a portion of, the extension options are not exercised and additional time is required by the Foundation to initiate a new RFP and subsequent Agreement, the Supplier agrees to continue to provide goods and/or services to the Participating Public or Private Agencies on a month to month basis, for a period not to exceed six (6) months, at the prices, terms and conditions currently at the Agreement expiration date.
8. Right to Terminate. Foundation has the right to terminate this Agreement for any reason, without penalty, at any time by providing Supplier with written notice of the termination at least thirty (30) days in advance.

QUARTERLY FEES & REPORTING

9. Accounting and Right to Audit. Supplier shall, at its expense, maintain accounting of all purchases made by Participating Public or Private Agencies. The Foundation reserves the right to audit the accounting for a period of four (4) years from the date the Foundation receives the accounting. In the event of such an audit, the requested materials shall be provided at the location designated by the Foundation.
10. Quarterly Fees and Reports. Supplier shall pay the Foundation a quarterly administrative fee in the amount of 2% of the total purchase invoice, less taxes for all purchases by Participating Public or Private Agencies under the awarded RFP, and shall provide the Foundation with an electronic accounting report, in a format prescribed by the Foundation, summarizing all purchases under the Agreement. A sample of the reporting format appears in Attachment 2. Quarterly fees and reports shall be made with respect to all purchases shipped and billed pursuant to the Agreement for the applicable quarter. Quarterly reports are due within fifteen (15) calendar days after the conclusion of the preceding quarter. Quarterly administrative fees applicable to each quarter, are due within thirty (30) days of the end of each calendar quarter. The Foundation reserves the right, upon thirty (30) days advance notice to the Supplier, to change the prescribed reporting format. Administrative fee payments shall be made by check to the Foundation for California Community Colleges.
11. Errors and Omissions on Quarterly Reporting and Overpayment of Administrative Fee to the Foundation. Supplier is provided ninety (90) days or until the conclusion of the subsequent quarter (whichever comes first) from when a quarterly report was due or submitted, to correct error(s) and/or omission(s) on a quarterly report; and/or to recover an overpayment of the administrative fee from the Foundation. Once the ninety (90) days or the conclusion of the subsequent quarter (whichever comes first) has lapsed, the Foundation reserves the right to retain the amount of the overpaid administrative fee. The Foundation also reserves the right to recover any unpaid administrative fee(s) from the Supplier discovered during an audit conducted pursuant to Section 10 above, and/or the correction of error(s) and/or omission(s) on quarterly report(s).
12. Right to Compare Records. The Foundation or its designee may, at the Foundation's sole discretion, compare Participating Public or Private Agency Records with quarterly reports submitted by Supplier. If there is a discrepancy, the Foundation will notify the Supplier in writing. The Supplier will have thirty (30) days from the date of such notice to resolve the discrepancy to the Foundation's reasonable satisfaction. If the Supplier does not resolve the said discrepancy, the Foundation shall have the right to engage outside services to conduct an independent audit of the Supplier's quarterly reports. The Supplier shall be obligated to reimburse any and all of the Foundation's costs and expenses related to or connected with the record and report reviews; the audit; Foundation staff time; and expenses, counsel, and collection.

GENERAL PROVISIONS

13. Supplier may submit for review new or enhanced products within the various Applications specified in the RFP #13-002. The Foundation will review the products to ensure they meet minimum requirements and at the Foundation's sole discretion, add products to the contract if deemed acceptable. Supplier must honor enhanced warranty and offer same tiered discount (for similar application) from original RFP response.
14. This Agreement constitutes the entire, complete, final and exclusive agreement between the parties with respect to the subject matter hereof and supersedes and replaces any and all prior and contemporaneous communications between Foundation and Supplier regarding such subject matter. Any terms and conditions which are additional to or different from the terms and conditions of this Agreement are hereby deemed rejected by Foundation and shall not be of any effect or in any way binding upon Foundation. To the extent that the terms and conditions of this Agreement conflict with, or are in any way inconsistent with, the terms and conditions of any exhibit hereto, the terms and conditions of this Agreement will prevail. The exhibits will be given precedence as follows: (1) Mandatory Performance of Services Specifications (Exhibit A); (2) Pricing (Exhibit B); (3) Request for Proposal or RFP (Exhibit C); and (4) Supplier Response to the RFP (Exhibit D).
15. Any use of the Foundation or CollegeBuys name or logo by the Supplier in marketing materials including but not limited to: press releases, print pieces, broadcast emails, and website postings, requires prior review and written approval from the Foundation.
16. If any action at law or in equity is brought to enforce or interpret the provisions of this Agreement, the prevailing party shall be entitled to reasonable attorney's fees and costs in addition to any other relief to which the prevailing party may be entitled.
17. This Agreement and the Foundation's rights and obligations hereunder may be assigned, at the Foundation's sole discretion, to an existing or newly established legal entity that has the authority and capacity to perform the Foundation's obligations hereunder. This Contract shall not be assignable by the Contractor in whole or in part without the written consent of the Foundation. For the purpose of this paragraph, Foundation will not unreasonably prohibit Contractor from freely assigning its right to payment, provided that Contractor remains responsible for its obligations hereunder

All reports, notices, and other written or electronic communications given hereunder shall be delivered by email or by express delivery requiring signature on receipt to the addresses as set forth below. The Foundation may, by written or electronic notice delivered to the Supplier, designate any different electronic or physical addresses to which subsequent reports, notices or other communications shall be sent.

A. Foundation

Foundation for California Community Colleges
1102 Q Street
Sacramento, CA 95814
Attn: CollegeBuys Program
Email: jsales@foundationccc.org and CollegeBuys@foundationccc.org

B. Supplier

Krueger International Inc.
Address: 1330 Bellevue St. Box 8100
Green Bay, WI 54308-8100
Attn: Trevor Deily
Phone: 415-252-0913
Email: trevor.deily@ki.com

18. Severability. If any provision of this Agreement shall be deemed to be, or shall in fact be, illegal, inoperative, or unenforceable, the same shall not affect any other provision or provisions herein contained or render the same invalid, inoperative, or unenforceable to any extent whatever.
19. This Agreement may not be effectively amended, changed, modified, altered, or terminated without the prior written consent of the parties hereto.
20. General Indemnity. Each party to this Agreement (“Indemnitor”) agrees to indemnify, defend and hold harmless the other, and its directors, officers, employees, successors and assigns (collectively, “Indemnitees”) against any and all losses, liabilities, claims, actions, suits, proceedings, penalties, fines, damages, costs or expenses, including, but not limited to, reasonable attorneys’ fees (including fees and disbursements of in-house and outside counsel), property damage, loss of use, maintenance, cure, or wages, and personal injury or illness and/or death, resulting from, arising out of, or connected with: (a) breach by Indemnitor of this Agreement; and (b) the performance of services or any error, act or omissions related to the same by Indemnitor or its employees, subcontractors, or any person or entity for whom the Indemnitor is responsible under this Agreement. The Indemnitor assumes no liability for the sole negligence or willful misconduct of the Indemnitees. It is the intention of the Parties that where the fault of Foundation and Supplier is determined to have been contributory to a matter subject to this Section 21, principles of comparative fault shall be followed and each party shall bear the proportionate cost of any share of such proportional comparative fault and pay such proportionate cost of any defense and indemnity attributable to the fault of that party, its directors, officers, employees, subcontractors, or any person or entity for whom the Indemnitor is responsible under this Agreement.

21. This Agreement shall be governed exclusively by and construed in accordance with the applicable laws of the State of California, by a California court of appropriate jurisdiction, as a contract executed and delivered within the State of California.
22. This Agreement shall inure to the benefit of and shall be binding upon the Foundation, the Supplier, and any successor and assign thereto subject, however, to the limitations contained herein.

IN WITNESS WHEREOF, the Foundation for California Community Colleges has caused this Agreement to be executed in its name, and the Supplier has caused this Agreement to be executed in its name, all as of the date first above written.

FOUNDATION FOR CALIFORNIA COMMUNITY COLLEGES

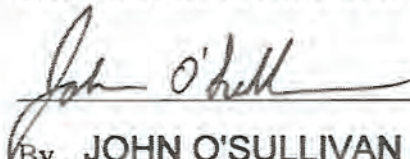
By JOHN O'SULLIVAN
[typed name]
Title VP of Finance & CFO
Date 10/2/13

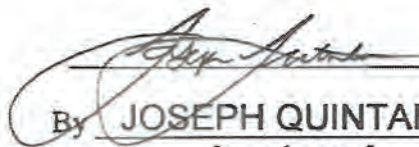
By JOSEPH QUINTANA
[typed name]
Title VP of Program Development
Date 10/2/13

SUPPLIER: Krueger International, Inc.

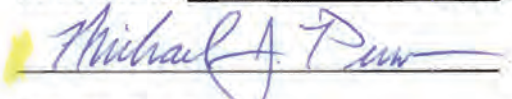
By Michael Pum
[typed name]
Title Assistant Secretary
Date 10/15/2013



CERTIFICATE OF LIABILITY INSURANCE

DATE(MM/DD/YYYY)
10/09/2013

THIS CERTIFICATE IS ISSUED AS A MATTER OF INFORMATION ONLY AND CONFERS NO RIGHTS UPON THE CERTIFICATE HOLDER. THIS CERTIFICATE DOES NOT AFFIRMATIVELY OR NEGATIVELY AMEND, EXTEND OR ALTER THE COVERAGE AFFORDED BY THE POLICIES BELOW. THIS CERTIFICATE OF INSURANCE DOES NOT CONSTITUTE A CONTRACT BETWEEN THE ISSUING INSURER(S), AUTHORIZED REPRESENTATIVE OR PRODUCER, AND THE CERTIFICATE HOLDER.

IMPORTANT: If the certificate holder is an ADDITIONAL INSURED, the policy(ies) must be endorsed. If SUBROGATION IS WAIVED, subject to the terms and conditions of the policy, certain policies may require an endorsement. A statement on this certificate does not confer rights to the certificate holder in lieu of such endorsement(s).

PRODUCER Aon Risk Services Central, Inc. Green Bay WI Office 111 N. Washington Street, Suite 300 P. O. Box 23004 Green Bay WI 54305-3004 USA	CONTACT NAME: PHONE (A/C. No. Ext): (920) 437-7123 FAX (A/C. No.): (920) 437-2401		
	E-MAIL ADDRESS:		
INSURED Krueger International Inc. PO Box 8100 Green Bay WI 54308 USA	INSURER(S) AFFORDING COVERAGE		NAIC #
	INSURER A: Federal Insurance Company		20281
	INSURER B:		
	INSURER C:		
	INSURER D:		
	INSURER E:		

COVERAGES **CERTIFICATE NUMBER: 570051676885** **REVISION NUMBER:**

THIS IS TO CERTIFY THAT THE POLICIES OF INSURANCE LISTED BELOW HAVE BEEN ISSUED TO THE INSURED NAMED ABOVE FOR THE POLICY PERIOD INDICATED. NOTWITHSTANDING ANY REQUIREMENT, TERM OR CONDITION OF ANY CONTRACT OR OTHER DOCUMENT WITH RESPECT TO WHICH THIS CERTIFICATE MAY BE ISSUED OR MAY PERTAIN, THE INSURANCE AFFORDED BY THE POLICIES DESCRIBED HEREIN IS SUBJECT TO ALL THE TERMS, EXCLUSIONS AND CONDITIONS OF SUCH POLICIES. LIMITS SHOWN MAY HAVE BEEN REDUCED BY PAID CLAIMS. **Limits shown are as requested**

INSR LTR	TYPE OF INSURANCE	ADDL INSR	SUBR WVD	POLICY NUMBER	POLICY EFF (MM/DD/YYYY)	POLICY EXP (MM/DD/YYYY)	LIMITS	
A	GENERAL LIABILITY <input checked="" type="checkbox"/> COMMERCIAL GENERAL LIABILITY CLAIMS-MADE <input checked="" type="checkbox"/> OCCUR <input checked="" type="checkbox"/> Contractual Liability GEN'L AGGREGATE LIMIT APPLIES PER: <input type="checkbox"/> POLICY <input checked="" type="checkbox"/> PRO-JECT <input type="checkbox"/> LOC			35767561 SIR applies per policy terms & conditions	07/01/2013	07/01/2014	EACH OCCURRENCE	\$1,000,000
							DAMAGE TO RENTED PREMISES (Ea occurrence)	Included
							MED EXP (Any one person)	\$5,000
							PERSONAL & ADV INJURY	\$1,000,000
							GENERAL AGGREGATE	\$5,000,000
							PRODUCTS - COMP/OP AGG	\$2,000,000
A	AUTOMOBILE LIABILITY <input checked="" type="checkbox"/> ANY AUTO <input type="checkbox"/> ALL OWNED AUTOS <input type="checkbox"/> HIRED AUTOS <input checked="" type="checkbox"/> Contractual Liability <input type="checkbox"/> SCHEDULED AUTOS <input type="checkbox"/> NON-OWNED AUTOS			73509069	07/01/2013	07/01/2014	COMBINED SINGLE LIMIT (Ea accident)	\$1,000,000
							BODILY INJURY (Per person)	
							BODILY INJURY (Per accident)	
							PROPERTY DAMAGE (Per accident)	
A	<input checked="" type="checkbox"/> UMBRELLA LIAB <input checked="" type="checkbox"/> OCCUR <input type="checkbox"/> EXCESS LIAB <input type="checkbox"/> CLAIMS-MADE <input type="checkbox"/> DED <input type="checkbox"/> RETENTION			79880404	07/01/2013	07/01/2014	EACH OCCURRENCE	\$1,000,000
							AGGREGATE	\$1,000,000
A	WORKERS COMPENSATION AND EMPLOYERS' LIABILITY ANY PROPRIETOR / PARTNER / EXECUTIVE OFFICER/MEMBER EXCLUDED? (Mandatory in NH) If yes, describe under DESCRIPTION OF OPERATIONS below			71704434 SIR applies per policy terms & conditions	07/01/2013	07/01/2014	<input checked="" type="checkbox"/> WC STATUTORY LIMITS <input type="checkbox"/> OTH-ER E.L. EACH ACCIDENT	\$1,000,000
							E.L. DISEASE-EA EMPLOYEE	\$1,000,000
							E.L. DISEASE-POLICY LIMIT	\$1,000,000
A	Bus Auto Damage			73509069 Auto Policy	07/01/2013	07/01/2014	Comprehensive Deductible	\$1,000
							Collision Deductible	\$5,000

DESCRIPTION OF OPERATIONS / LOCATIONS / VEHICLES (Attach ACORD 101, Additional Remarks Schedule, if more space is required)
 RE: Administrative Services Agreement #CB 13-013.
 The Foundation and each Participating Public or Private Agency procuring Flooring Materials hereunder shall be named additional insured to the Commercial General Liability insurance policy of the Supplier and its Subcontractors for each specific procurement of Furniture and Fixtures, as required by the above mentioned services agreement.

CERTIFICATE HOLDER**CANCELLATION**

Foundation for California Community colleges Attn: CollegeBuys Program 1102 Q Street Sacramento CA 95814 USA	SHOULD ANY OF THE ABOVE DESCRIBED POLICIES BE CANCELLED BEFORE THE EXPIRATION DATE THEREOF, NOTICE WILL BE DELIVERED IN ACCORDANCE WITH THE POLICY PROVISIONS.
	AUTHORIZED REPRESENTATIVE <i>Aon Risk Services Central, Inc.</i>

Holder Identifier :

Certificate No : 570051676885



FOUNDATION *for* CALIFORNIA
COMMUNITY COLLEGES

Furniture and Fixtures Applications CB13-013

Exhibit A: Mandatory Performance Specifications

(RFP 13-002, Vendor Response, Exhibit A)

EXHIBIT A
Pages 26 through 31

RFP #13-002
FURNITURE and FIXTURES APPLICATIONS

Mandatory Performance and Service Specifications

Listed below are the specific **Mandatory** performance and service requirements for the Furniture and Fixtures Applications subject to this RFP. Each requirement includes a specific explanation of its value to the Participating Agencies, and is considered mandatory to provide. The document must be acknowledged in the responder's submittal by a responsible and authorized employee or officer of the Vendor submitting the RFP Proposal.

Criterion/ Description	Item	Requirement	Justification
-A- Manufacturer/ Factory Requirements, All Pricing Categories	A.1	Provide Participating Agency with the ability to modify current standard product models within reason to accommodate project requirements without being cost or time prohibitive.	Allows for effective accommodation of Participating Agency requirements; minimizes potential for product replacement within shorter timeframe, reducing operational and capital expenditures for the Participating Agency.
	A.2	Provide a minimum written warranty to cover Parts and Labor for 15 years, 18 hours a day, 6 days a week, or 12 years, 24 hours a day, 7 days a week as "normal use", at no additional charge to the Participating Agency. No pro-rated warranties will be accepted. Allowable exceptions to the time frames noted above: Electric Motors, Walls, Flooring Products, minimum 10 years; Wood Veneer, minimum 1 year, and Upholstery and Pneumatic Cylinders, Site Furnishings, minimum 5 years.	Reduces district operating costs over the life of product; sets realistic expectations for products within district environment; engages manufacturer to produce appropriate products for environment, which maximizes effectiveness of partnership.
	A.3	Provide finishes which are non-proprietary to a specific manufacturer. Manufacturer must be willing to share finish information and access with other manufacturers who are awarded a part of shared projects, at no cost to the District or other Vendors, to assure design continuity throughout project (i.e.: Laminates, Paint Finishes, Fabrics).	Allows for cohesive design throughout environment, increasing installation effectiveness; minimizes cost to district, leveraging budget dollars; engages manufacturer to produce appropriate products for environment, which maximizes effectiveness of partnership
	A.4	All products will be considered FOB Destination (receiving location of the buyer or pre-determined Installer's Warehouse location), as directed by the Participating Agency with the Vendor managing all freight claims following shipment from the factory. Manufacturer must confirm that Vendor will not invoice the Participating Agency for replacement of freight damaged product regardless of future invoice credit potential.	Reduces labor costs for Participating Agency to manage additional paperwork for details that are outside of their control, resulting in financial savings.
	A.5	Accommodate Participating Agency's requirements for Invoicing format, timing, and other supporting documentation as required.	Expedites payment to Vendor by reducing potential communication issues.

<p align="center">-B- Manufacturer/ Field Requirements, All Pricing Categories</p>	B.1	Provide Factory Certified Warranty Repair personnel for all Participating Agencies. Provide documentation of Certification Process.	Reduces potential labor issues or costs for repairs after installation, saving the Agency money and time.
	B.2	Provide Participating Agency, prior to the placement of any order that will utilize 3rd Party Services for Installation, a list of Authorized Factory Certified Installation Personnel for Participating Agency projects. Participating Agency must pre-approve Local Service Provider prior to order placement. Note: Does not apply to Classification 16, Site Furniture.	Reduces the potential for costly project delays; insures installation of products in safest manner; reduces potential labor costs for repairs after installation; allows the Participating Agency to utilize local service providers as desired.
	B.3	Provide local manufacturer representation (may be in addition to a dealer representative) with a minimum of two (2) years of Higher Education Project experience, who will facilitate product specification accuracy, technical specifications for building interface, project scheduling, shipment and warranty issues with Service Provider.	Assures effective communication between factory and district, which can save money for the district during the project and in the future; requires Vendor to produce adequate documentations of technical requirements for other project Vendors, reducing potential mistakes or delays.
	B.4	Whenever possible, coordinate all products on the project order to ship complete and directly to end user site. Less Than Truckload (LTL) shipments must be directed to the Vendor's receiving entity.	Reduces costs of double handling of products; reduces overall project timeline; requires the Service Providers to be fully aware of all aspects for project success.
	B.5	Assume all financial responsibility for additional handling, storage or other required services, beyond the thirty (30) days required as part of this agreement, should the product arrive ahead of identified project schedule. The Participating Agency agrees to confirm the project schedule and installation timing in writing to the Vendor no later than twelve (12) weeks from targeted installation.	Requires ownership of performance and project success, reducing costs; sets realistic expectations for communications between the Manufacturer and the Participating Agency, reducing overall costs.
<p align="center">-C- Services/ Specification Planning, All Pricing Categories</p>	C.1	Using the Product Performance Specifications listed in Section H - Performance Specifications, recommend only those specific manufacturer's product solutions that <i>best</i> meet the Participating Agency business requirements. It is the Vendor's responsibility to make that determination and recommend only products that demonstrate those inherent qualities.	Requires Manufacturer to have intimate knowledge of both Participating Agency needs and manufacturing capability, increasing the probability of effective and appropriate solutions will be presented.
	C.2	Develop detailed specifications and quotations that include all product requirements, finishes, product tagging and any appropriate separate fees or charges based upon contractual requirements, for review and approval by the Participating Agency Team.	Requires Vendors to take ownership of accuracy and effectiveness of the final product solution between manufacturer and district, saving potential expense in revisions or corrections once the order is placed.

	C.3	In addition to the original project layout, provide maximum of two (2) layout revisions (not "options") in the specific areas intended to receive product, to confirm spacing and building interface where needed for power and data). Note: Does not apply to Classification 16, Site Furniture.	Requires Service Providers to effectively and efficiently plan the project requirements, reducing time and costs for the Participating Agency.
	C.4	Conduct thorough quotation, drawing, and graphic product review, explicitly defining every detail of the product specification with the Participating Agency representative to confirm understanding of all aspects of the recommended order. Participating Agency sign-off of Vendor documentation does not ameliorate manufacturer of responsibilities identified in C.5.	Requires Service Providers to communicate in a manner that fully engages the end user contact in the specifics of the product solution, saving potential expense in revisions; reduces the amount of time the district must spend in communicating the solution details to the end user, saving the Participating Agency money.
	C.5	Accept complete responsibility for all product recommendations per application, specifications and accuracy of quotations provided to Participating Agency for purchase.	Demands accountability from Vendor for accuracy; Provides a single point of responsibility for ease of reconciliation of errors, potentially saving the Participating Agency money.
	C.6	Communicate any and all changes to the schedule, requirements, or expectations in writing, addressed to the Participating Agency contact and copied to purchasing contact. Agency commits to providing written confirmation of site availability for installation no later than twelve (12) weeks prior to scheduled date.	Reduces the possibility of verbal commands that could incur expense to the Participating Agency. Provides Vendor with assurance that spaces will be ready for installation in time to allow production can be delayed without financial impact to the Vendor.
—D— Services/ Implementation Planning, Pricing Categories B & C Only	D.1	Provide the Participating Agency Project Manager with access information for all Vendor support members, including cell phone and email addresses. The Participating Agency contact will provide the Participating Agency contact data as necessary.	Minimizes time required to contact appropriate parties during project process, potentially reducing cost.
	D.2	Provide to and review with Participating Agency a complete set of installation documents, order acknowledgement/confirmation and project schedule with the Participating Agency Project Manager at least ten (10) days prior to the installation date.	Defines all requirements of the Service Providers to the Participating Agency in a timely manner to implement effectively, assuring compliance and access to site.
	D.3	Outline all site access requirements to the specified Participating Agency contact and confirm security clearance and requirements no later than ten (10) business days prior to installation.	Assures all products will function well from the first day of installation, and will reduce potential for time lost due to lack of utilization.
	D.4	Provide Factory Certified Installation personnel for all Participating Agency projects. Provide documentation of Certification Process. Accept full responsibility for project delays incurred due to slow installation by installers.	Reduces the potential for costly project delays; insures installation of products in safest manner; reduces potential labor costs for repairs after installation.

	D.5	Provide the Participating Agency contact with access information for all Vendor support members, including cell phone and email addresses. The Participating Agency contact will provide the Participating Agency contact data as necessary.	Minimizes time required to contact appropriate parties during project process, potentially reducing cost and increasing client satisfaction.
	D.6	Conduct pre-installation walk-through with the Participating Agency Project Manager immediately prior to installation to determine condition of site and to agree to the level of site protection required.	Conduct pre-installation walk-through with the Participating Agency Project Manager immediately prior to installation to determine condition of site and to agree to the level of site protection required.
<p align="center">E</p> <p align="center">Services/ Implementation Planning, Pricing Category C Only</p>	E.1	Generate project documents in Revit or similar 3-D modeling program that illustrates product placement and building interface, provide for 3D representation of layouts if desired by client, and that are coded for product type for installation.	Provides a single point of reference for all trades, which can be transferred between organizations for utilization, reducing errors; provides district with As Built plans for future use; reduces communication errors, saving the Participating Agency money.
	E.2	Produce field verifications of all spaces to be furnished, using architectural plans as the basis for product layouts (Note: if construction has not been completed prior to specification development, rooms must be verified by service provider for fit and quantities). All revisions are to be made prior to production, and be documented to the Participating Agency in both written and graphic format (CAD).	Requires Service Providers to take ownership and responsibility of the finished product, rather than the Participating Agency representative, who will not have the experience in this application; reduces the potential for installation challenges and costly replacement errors.
	E.3	For products that require DSA oversight and approval for connectivity to a building, Vendor must agree to use DSA approved project plans for development of specifications, track changes to those plans, and revise connections and specifications if required to obtain DSA approval for Participating Agency.	Reduces potential installation and approval delays, as well as payment timeframe to Vendor from Participating Agency.
	E.4	Develop and maintain project schedule in Excel or MS Project format, communicating developments and changes as needed. Issue updated versions when requested by the Participating Agency Project Manager, or at a minimum of once a month, until project is completed.	Increases utilization of technology for effective communications between parties.
	E.5	Participate in or conduct on-site project scheduling meetings at least twice prior to receipt of product to assure effective communication between the construction team, user groups, and sub-contractors who will integrate with product installers.	Engages all parties in the project to reduce potential misunderstandings about expectations and requirements from all parties, reducing the potential for costly errors.
	E.7	Obtain all required permits for furniture installation, at no additional charge to the Participating Agency (with the exception of hard-wire connections if required by local code).	Assures smooth installation process from inspector's perspective, avoiding potentially expensive delays in the project.

<p align="center">—F— Services/ Implementation Process, Pricing Categories B & C Only</p>	F.1	Provide on-site Project Management representation, with complete installation documentation, at all times during installation (note: this may be provided by Factory Certified Lead Installer).	Assures prompt resolution of issues during critical project timeframe, reducing costs.
	F.2	Protect all areas of Vendor product installation, conveyances and paths of travel from damage due to transport or installation of Vendor products. Assume responsibility for site damage caused by Vendor crews and sub-contractors. Resolve issues within ten (10) days.	Reduces costs to participating agency as well as potential delays to opening new facilities.
	F.3	Prepare all products for use, including removal of extraneous packaging, stickers or labels (other than manufacturer model and ordering information labels), and provide appropriate user instructions at each appropriate location.	Assures all products will function well from the first day of installation, and will reduce potential for time lost due to lack of utilization.
	F.4	Remove all trash from site, and leave workspace broom clean, daily. Agree to minimize the use of wrapping material as much as reasonably feasible, and recycle as much wrapping material as possible.	Increases partnership with local Service Providers in achieving both district and state requirements for waste reduction; reduces the Participating Agency cleaning and recycling expense.
	F.5	Facilitate on-site installation review and develop project Punch List for Project Manager approval. Repair or replace all items in question within ten (10) business days, at no charge to the Participating Agency. The Participating Agency may withhold a minimum of ten percent (10%) of invoice value if this requirement is not met.	Minimizes user impact of potential issues not caused by user or district; eliminates additional cost of manpower for labor or management of Punch List items; expedites payment of Vendor invoices.
	F.6	Assume all financial responsibility for site damage incurred by the installation team. Repair to the Participating Agency's satisfaction all damage within ten (10) business days.	Minimizes buyer cost for damage by others; assigns accountability to the Service Providers of responsibility of the installation team.
	F.7	Conduct Post-Installation review with the Participating Agency representative and Purchasing contact to determine effectiveness and areas of improvement for future projects.	Strengthens partnership in the Participating Agency's success with the Service Providers, increases their knowledge of issues less obvious, relative to the learning environment.
<p align="center">—G— Services/ Implementation Follow-Up, All Pricing Categories</p>	G.1	Provide the Participating Agency Project Manager and the Purchasing Department of the Participating Agency with detailed invoice, in a pre-determined format, for approval and payment.	Hastens payment of Vendor invoices, reducing future cost to buyers.
	G.2	Provide complete project documentation package to Participating Agency representative, in electronic format, including PDF, AutoCAD and REVIT (or like program) drawings as defined by pricing category, written warranty documentation, MSDS sheets, and part diagrams for items provided.	Provides client with detailed record of project requirements, and organizes future reference information into one succinct package, reducing staff time required to locate information in the future.

	<p>G.3 Provide warranty service response within forty-eight (48) hours of the Participating Agency request. Provide service or product requirements within ten (10) business days of determination of need. Schedule all services so as not to interfere with activities within space, at no charge to the Participating Agency.</p>	<p>Reduces impact of failures on Participating Agency personnel and staff, increasing their ability to focus on primary responsibilities.</p>
	<p>G.4 Along with Project Invoices, provide summary report detailing the percentage of recycled materials used in those products provided on said invoices.</p>	<p>Allows Participating Agencies to conform to reporting requirements for recycled materials.</p>
<p align="center">—H— Performance Specifications/ All Products Offered</p>	<p>DURABILITY: Product must demonstrate the ability to last a minimum of 25 to 30 years, while functioning well within a changing and arduous environment; Products must have the ability to maintain their original appearance over life, with normal Wear and Tear as defined as 18 hours a day, 6 days a week; Products must withstand movement between rooms or buildings over life (applies to movable items); Finishes and details must be designed to take constant impact from moving or usage; Products must be designed so parts cannot be readily removed by user without unique tools; Products must be able to be readily refinished (within reason) to accommodate change in aesthetics over its expected long life; All product finishes recommended will inherently resist user abuse.</p> <p>TOTAL COST OF OWNERSHIP: Products should require minimal maintenance by either the Agency or manufacturer to retain usefulness for 25 to 30 years; Products must inherently reduce manpower and time required to clean the facilities around the Vendor's products (floors, etc.); Products must offer field replaceable parts, by either manufacturer or district staff, once past warranty period.</p> <p>EASE OF USE: Products must inherently allow for easy changeability within a given room or space, as well as within campus environment within a variety of applications, over its expected long life; Product offering from Vendor must provide appropriate utilization in a wide range of typical applications found within a community college environment; Products should be able to be reconfigured simply and efficiently by either the Vendor or Agency's personnel, without more than minor disruption to building or users, within reason (applies to moveable products).</p>	

I have read and understood the expectations defined in Exhibit A: Mandatory Performance and Service Expectations.

Name: 
Vendor: Krueger International, Inc.

Title: Assistant Secretary
Date: 9/3/13



FOUNDATION *for* CALIFORNIA
COMMUNITY COLLEGES

Furniture and Fixtures Applications CB13-013

Exhibit B: Pricing and Product Information

(RFP 13-002, Vendor Response, Exhibit B)

**EXHIBIT B:
PRICE SHEET DISCOUNT OFF LIST, AS OF 4/7/2015**

VENDOR:

Krueger International, Inc. (KI)

CLASSIFICATION 1: ACADEMIC ENVIRONMENTS/ TRADITIONAL STUDENT DESKS		Max Awards: 3	CATEGORY A: DROP SHIP (MINIMUM DISCOUNT OFF LIST PRICE)					CATEGORY B: DELIVERED DISCOUNT OFF LIST PRICE) (MINIMUM					CATEGORY C: TURNKEY INSTALLATION (MINIMUM DISCOUNT OFF LIST PRICE)				
ITEM #	APPLICATION: Handed Tablet Arm Chairs	VENDOR PRODUCT RECOMMENDATION:	TIER #1 \$1 - \$50,000	TIER #2 \$50,001 - \$150,000	TIER #3 \$150,001 - \$300,000	TIER #4 \$300,001 - \$500,000	TIER #5 \$500,001+ IS NEGOTIABLE	TIER #1 \$1 - \$50,000	TIER #2 \$50,001 - \$150,000	TIER #3 \$150,001 - \$300,000	TIER #4 \$300,001 - \$500,000	TIER #5 \$500,001+ IS NEGOTIABLE	TIER #1 \$1 - \$50,000	TIER #2 \$50,001 - \$150,000	TIER #3 \$150,001 - \$300,000	TIER #4 \$300,001 - \$500,000	TIER #5 \$500,001+ IS NEGOTIABLE
1.1	Student Tablet Armchair, 4 Leg, Poly Shell	Piretti Grazie Collection	51.5%	53.5%	53.5%	53.5%	53.5%	45.5%	47.8%	47.8%	47.8%	47.8%	45.2%	47.2%	47.2%	47.2%	47.2%
1.2	Student Tablet Armchair, Oversized Tablet, 4 Leg, Poly Shell	Piretti Grazie Collection	51.5%	53.5%	53.5%	53.5%	53.5%	45.5%	47.8%	47.8%	47.8%	47.8%	45.2%	47.2%	47.2%	47.2%	47.2%
ITEM #	APPLICATION: Separate Desks and Chairs	VENDOR PRODUCT RECOMMENDATION:	TIER #1 \$1 - \$50,000	TIER #2 \$50,001 - \$150,000	TIER #3 \$150,001 - \$300,000	TIER #4 \$300,001 - \$500,000	TIER #5 \$500,001+ IS NEGOTIABLE	TIER #1 \$1 - \$50,000	TIER #2 \$50,001 - \$150,000	TIER #3 \$150,001 - \$300,000	TIER #4 \$300,001 - \$500,000	TIER #5 \$500,001+ IS NEGOTIABLE	TIER #1 \$1 - \$50,000	TIER #2 \$50,001 - \$150,000	TIER #3 \$150,001 - \$300,000	TIER #4 \$300,001 - \$500,000	TIER #5 \$500,001+ IS NEGOTIABLE
1.3	Single Student Desk, 4 Leg, Metal Frame, Laminate or Polycarbonate Top	KI Intellect Wave (previously awarded)	51.5%	53.5%	53.5%	53.5%	53.5%	45.5%	47.8%	47.8%	47.8%	47.8%	45.2%	47.2%	47.2%	47.2%	47.2%
1.4	Double Student Desk, Cantilever Leg, Metal Frame, Laminate or Polycarbonate Top	KI Intellect Wave (previously awarded)	51.5%	53.5%	53.5%	53.5%	53.5%	45.5%	47.8%	47.8%	47.8%	47.8%	45.2%	47.2%	47.2%	47.2%	47.2%
1.5	Student Chair, 4 Leg, Armless, Poly Shell	Piretti Grazie Collection	51.5%	53.5%	53.5%	53.5%	53.5%	45.5%	47.8%	47.8%	47.8%	47.8%	45.2%	47.2%	47.2%	47.2%	47.2%
1.6	Student Chair, Cantilever Base, Armless, Poly Shell	Piretti Grazie Collection	51.5%	53.5%	53.5%	53.5%	53.5%	45.5%	47.8%	47.8%	47.8%	47.8%	45.2%	47.2%	47.2%	47.2%	47.2%
1.7	Student Seating, Pedestal Base, Arm and Armless versions, Poly Back, Poly or Uph Seat Option	Piretti Grazie Collection	51.5%	53.5%	53.5%	53.5%	53.5%	45.5%	47.8%	47.8%	47.8%	47.8%	45.2%	47.2%	47.2%	47.2%	47.2%
CLASSIFICATION 2: ACADEMIC ENVIRONMENTS/ CONTEMPORARY STUDENT DESKS		Max Awards: 3	CATEGORY A: DROP SHIP DISCOUNT OFF LIST PRICE) (MINIMUM					CATEGORY B: DELIVERED & INSTALLED (MINIMUM DISCOUNT OFF LIST PRICE)					CATEGORY C: TURNKEY INSTALLATION (MINIMUM DISCOUNT OFF LIST PRICE)				
ITEM #	APPLICATION: Non-Handed Student Desks	VENDOR PRODUCT RECOMMENDATION:	TIER #1 \$1 - \$50,000	TIER #2 \$50,001 - \$150,000	TIER #3 \$150,001 - \$300,000	TIER #4 \$300,001 - \$500,000	TIER #5 \$500,001+ IS NEGOTIABLE	TIER #1 \$1 - \$50,000	TIER #2 \$50,001 - \$150,000	TIER #3 \$150,001 - \$300,000	TIER #4 \$300,001 - \$500,000	TIER #5 \$500,001+ IS NEGOTIABLE	TIER #1 \$1 - \$50,000	TIER #2 \$50,001 - \$150,000	TIER #3 \$150,001 - \$300,000	TIER #4 \$300,001 - \$500,000	TIER #5 \$500,001+ IS NEGOTIABLE
2.1	Student Desk, Double Entry, Sled Base, Auto-return Seat, Laminate Top, Poly Shell	KI 360 Desk with All Approved Shells (previously awarded)	53.4%	55.4%	55.4%	55.4%	55.4%	48.0%	50.0%	50.0%	50.0%	50.0%	47.3%	49.3%	49.3%	49.3%	49.3%
2.2	Student Desk, Double Entry, Sled Base, Swiveling Seat, Laminate Top, Poly Shell	KI 360 Desk with All Approved Shells (previously awarded)	53.4%	55.4%	55.4%	55.4%	55.4%	48.0%	50.0%	50.0%	50.0%	50.0%	47.3%	49.3%	49.3%	49.3%	49.3%
CLASSIFICATION 3: ACADEMIC ENVIRONMENTS/ DYNAMIC STUDENT DESKS		Max Awards: 3	CATEGORY A: DROP SHIP DISCOUNT OFF LIST PRICE) (MINIMUM					CATEGORY B: DELIVERED & INSTALLED (MINIMUM DISCOUNT OFF LIST PRICE)					CATEGORY C: TURNKEY INSTALLATION (MINIMUM DISCOUNT OFF LIST PRICE)				
ITEM #	APPLICATION: Dynamic Student Desks	VENDOR PRODUCT RECOMMENDATION:	TIER #1 \$1 - \$50,000	TIER #2 \$50,001 - \$150,000	TIER #3 \$150,001 - \$300,000	TIER #4 \$300,001 - \$500,000	TIER #5 \$500,001+ IS NEGOTIABLE	TIER #1 \$1 - \$50,000	TIER #2 \$50,001 - \$150,000	TIER #3 \$150,001 - \$300,000	TIER #4 \$300,001 - \$500,000	TIER #5 \$500,001+ IS NEGOTIABLE	TIER #1 \$1 - \$50,000	TIER #2 \$50,001 - \$150,000	TIER #3 \$150,001 - \$300,000	TIER #4 \$300,001 - \$500,000	TIER #5 \$500,001+ IS NEGOTIABLE
3.1	Caster Base Unit w/Swiveling Non-Handed Tablet, Range of Options	KI Learn2 (previously awarded)	51.5%	53.5%	53.5%	53.5%	53.5%	45.8%	47.8%	47.8%	47.8%	47.8%	45.2%	47.2%	47.2%	47.2%	47.2%
CLASSIFICATION 4: ACADEMIC ENVIRONMENTS/ STANDARD CLASSROOM PRODUCTS		Max Awards: 3	CATEGORY A: DROP SHIP DISCOUNT OFF LIST PRICE) (MINIMUM					CATEGORY B: DELIVERED & INSTALLED (MINIMUM DISCOUNT OFF LIST PRICE)					CATEGORY C: TURNKEY INSTALLATION (MINIMUM DISCOUNT OFF LIST PRICE)				
ITEM #	APPLICATION: Student Support Furniture	VENDOR PRODUCT RECOMMENDATION:	TIER #1 \$1 - \$50,000	TIER #2 \$50,001 - \$150,000	TIER #3 \$150,001 - \$300,000	TIER #4 \$300,001 - \$500,000	TIER #5 \$500,001+ IS NEGOTIABLE	TIER #1 \$1 - \$50,000	TIER #2 \$50,001 - \$150,000	TIER #3 \$150,001 - \$300,000	TIER #4 \$300,001 - \$500,000	TIER #5 \$500,001+ IS NEGOTIABLE	TIER #1 \$1 - \$50,000	TIER #2 \$50,001 - \$150,000	TIER #3 \$150,001 - \$300,000	TIER #4 \$300,001 - \$500,000	TIER #5 \$500,001+ IS NEGOTIABLE
4.1	Student Seating, 4 Leg, Armless, Poly Shell	Piretti Grazie Collection	51.5%	53.5%	53.5%	53.5%	53.5%						44.2%	47.2%	47.2%	47.2%	47.2%

**EXHIBIT B:
PRICE SHEET DISCOUNT OFF LIST, AS OF 4/7/2015**

4.2	Student Seating, Pedestal Base, Arm and Armless versions, Poly Back, Poly or Uph Seat Option	Piretti Grazie Collection	51,5%	53,5%	53,5%	53,5%	53,5%								44,2%	47,2%	47,2%	47,2%	47,2%			
4.3	Student Tables, Fixed Top, Steel Frame, Hard Plastic and/or Laminate Top, Range of Options	Backbone	51,5%	53,5%	53,5%	53,5%	53,5%								44,2%	47,2%	47,2%	47,2%	47,2%			
4.4	Student Tables, Adjustable Height Top (ADA Compliant), Steel Frame, Hard Plastic and/or Laminate Top	KI Genesis, WorkZone (previously awarded)	53,9%	55,9%	55,9%	55,9%	55,9%								47,0%	50,0%	50,0%	50,0%	50,0%			
4.5	Student Lab Stools, Backless, w/Casters, Poly and/or Uph Seat	KI WS-15 Stool, Mechanical and Laboratory Stools (previously awarded)	51,5%	53,5%	53,5%	53,5%	53,5%								44,2%	47,2%	47,2%	47,2%	47,2%			
4.6	Student Lab Stools, Backless, 4 Leg, Height Adj., Poly Seat	KI 600 Stool (previously awarded)	51,5%	53,5%	53,5%	53,5%	53,5%								45,2%	47,2%	47,2%	47,2%	47,2%			
4.7	Student Lab Stools w/Back, Arm and Armless versions, Sit/Stand Height Range, Poly Shell	KI Torsion, Glimmer, Strive, Intellect Wave (previously awarded)	51,5%	53,5%	53,5%	53,5%	53,5%								45,2%	47,2%	47,2%	47,2%	47,2%			
ITEM #	APPLICATION: Faculty Support Furniture	VENDOR PRODUCT RECOMMENDATION:	TIER #1 \$1 - \$50,000	TIER #2 \$50,001 - \$150,000	TIER #3 \$150,001 - \$300,000	TIER #4 \$300,001 - \$500,000	TIER #5 \$500,001+ IS NEGOTIABLE	TIER #1 \$1 - \$50,000	TIER #2 \$50,001 - \$150,000	TIER #3 \$150,001 - \$300,000	TIER #4 \$300,001 - \$500,000	TIER #5 \$500,001+ IS NEGOTIABLE	TIER #1 \$1 - \$50,000	TIER #2 \$50,001 - \$150,000	TIER #3 \$150,001 - \$300,000	TIER #4 \$300,001 - \$500,000	TIER #5 \$500,001+ IS NEGOTIABLE	TIER #1 \$1 - \$50,000	TIER #2 \$50,001 - \$150,000	TIER #3 \$150,001 - \$300,000	TIER #4 \$300,001 - \$500,000	TIER #5 \$500,001+ IS NEGOTIABLE
4.8	Faculty Teaching Desk, Laminate/Steel w/Single Center Drawer	KI Intellect Wave (previously awarded)	51,5%	53,5%	53,5%	53,5%	53,5%								45,2%	47,2%	47,2%	47,2%	47,2%			
4.9	Faculty Storage Unit, Steel, w/Doors and Shelves, Locking	KI 700 Series (previously awarded)	54,5%	56,5%	56,5%	56,5%	56,5%								48,6%	50,6%	50,6%	50,6%	50,6%			
4.10	Faculty Stool, Backless, Arm and Armless versions, Poly Seat, Height Adjustable	KI WS-15 Stool, Mechanical and Laboratory Stools (previously awarded)	51,5%	53,5%	53,5%	53,5%	53,5%								44,2%	47,2%	47,2%	47,2%	47,2%			
4.11	Faculty Stool, w/Back, Arm and Armless versions, Casters, Poly Back, Poly or Uph Seat Option, Height Adjustable	KI Torsion, Glimmer, Strive, Intellect Wave (previously awarded)	51,5%	53,5%	53,5%	53,5%	53,5%								45,2%	47,2%	47,2%	47,2%	47,2%			
4.12	Faculty Seating, 4 Leg, Arm and Armless versions, Poly Shell	KI Torsion, Glimmer, Dorsal, Strive, Intellect Wave (previously awarded)	51,5%	53,5%	53,5%	53,5%	53,5%								45,2%	47,2%	47,2%	47,2%	47,2%			
4.13	Faculty Seating, Pedestal Base, Arm and Armless versions, Poly or Uph Seat and Back Options, Height Adjustable	KI Torsion, Glimmer, Strive (previously awarded)	51,5%	53,5%	53,5%	53,5%	53,5%								45,2%	47,2%	47,2%	47,2%	47,2%			
4.14	Faculty Multi-Media Podium, Height Adjustable	KI Wharion (previously awarded)	52,5%	54,5%	54,5%	54,5%	54,5%								45,3%	49,3%	49,3%	49,3%	49,3%			
4.15	Faculty Multi-Media Podium, Fixed Height	KI Instruct	51,5%	53,5%	53,5%	53,5%	53,5%								45,2%	47,2%	47,2%	47,2%	47,2%			
ITEM #	APPLICATION: Computer Lab Support Furniture	VENDOR PRODUCT RECOMMENDATION:	TIER #1 \$1 - \$50,000	TIER #2 \$50,001 - \$150,000	TIER #3 \$150,001 - \$300,000	TIER #4 \$300,001 - \$500,000	TIER #5 \$500,001+ IS NEGOTIABLE	TIER #1 \$1 - \$50,000	TIER #2 \$50,001 - \$150,000	TIER #3 \$150,001 - \$300,000	TIER #4 \$300,001 - \$500,000	TIER #5 \$500,001+ IS NEGOTIABLE	TIER #1 \$1 - \$50,000	TIER #2 \$50,001 - \$150,000	TIER #3 \$150,001 - \$300,000	TIER #4 \$300,001 - \$500,000	TIER #5 \$500,001+ IS NEGOTIABLE	TIER #1 \$1 - \$50,000	TIER #2 \$50,001 - \$150,000	TIER #3 \$150,001 - \$300,000	TIER #4 \$300,001 - \$500,000	TIER #5 \$500,001+ IS NEGOTIABLE
4.16	Computer Lab Table, Laminate/Steel, Fixed and Folding Leg Options, Power/Data Accessories, Accessible Cableway Modesty Panel	KI Data Link (previously awarded)	52,3%	54,3%	54,3%	54,3%	54,3%								46,1%	48,1%	48,1%	48,1%	48,1%			
4.17	Computer Lab Table, Laminate/Steel, Adjustable Height (ADA Compliant), Power/Data Options	KI Genesis, WorkZone (previously awarded)	53,9%	55,9%	55,9%	55,9%	55,9%								48,0%	50,0%	50,0%	50,0%	50,0%			
4.18	Computer Lab Table, Laminate/Steel, Continuous Top and Shared Legs, Fixed Height, Laptop Storage and Power/Data Options, Accessible Cableway Modesty Panel	KI InTandem (previously awarded)	53,9%	55,9%	55,9%	55,9%	55,9%								48,0%	50,0%	50,0%	50,0%	50,0%			
CLASSIFICATION 5: ACADEMIC ENVIRONMENTS/ STUDY AREAS		Max Awards: 3	CATEGORY A: DROP SHIP DISCOUNT OFF LIST PRICE (MINIMUM					CATEGORY B: DELIVERED & INSTALLED (MINIMUM DISCOUNT OFF LIST PRICE					CATEGORY C: TURNKEY INSTALLATION (MINIMUM DISCOUNT OFF LIST PRICE									
ITEM #	APPLICATION: Study Area Tables	VENDOR PRODUCT RECOMMENDATION:	TIER #1 \$1 - \$50,000	TIER #2 \$50,001 - \$150,000	TIER #3 \$150,001 - \$300,000	TIER #4 \$300,001 - \$500,000	TIER #5 \$500,001+ IS NEGOTIABLE	TIER #1 \$1 - \$50,000	TIER #2 \$50,001 - \$150,000	TIER #3 \$150,001 - \$300,000	TIER #4 \$300,001 - \$500,000	TIER #5 \$500,001+ IS NEGOTIABLE	TIER #1 \$1 - \$50,000	TIER #2 \$50,001 - \$150,000	TIER #3 \$150,001 - \$300,000	TIER #4 \$300,001 - \$500,000	TIER #5 \$500,001+ IS NEGOTIABLE	TIER #1 \$1 - \$50,000	TIER #2 \$50,001 - \$150,000	TIER #3 \$150,001 - \$300,000	TIER #4 \$300,001 - \$500,000	TIER #5 \$500,001+ IS NEGOTIABLE
5.1	Study Tables, Fixed Height, Laminate/Steel	KI Venue, DataLink MP (previously awarded)	53,9%	55,9%	55,9%	55,9%	55,9%								48,0%	50,0%	50,0%	50,0%	50,0%			
5.2	Study Tables, Adjustable Height, Laminate/Steel	WorkUp, Toggle, KI Genesis, WorkZone (previously awarded)	53,9%	55,9%	55,9%	55,9%	55,9%								48,0%	50,0%	50,0%	50,0%	50,0%			
5.3	Study Tables, Fixed Height, Wood/Wood	KI CrossRoads (previously awarded)	52,9%	54,9%	54,9%	54,9%	54,9%								47,3%	49,3%	49,3%	49,3%	49,3%			
5.4	Study Tables, Adjustable Height, Wood/Steel	KI Genesis, WorkZone (previously awarded)	53,9%	55,9%	55,9%	55,9%	55,9%								48,0%	50,0%	50,0%	50,0%	50,0%			

**EXHIBIT B:
PRICE SHEET DISCOUNT OFF LIST, AS OF 4/7/2015**

ITEM #	APPLICATION: Study Area Seating	VENDOR PRODUCT RECOMMENDATION:	TIER #1	TIER #2	TIER #3	TIER #4	TIER #5	TIER #1	TIER #2	TIER #3	TIER #4	TIER #5	TIER #1	TIER #2	TIER #3	TIER #4	TIER #5					
			\$1 - \$50,000	\$50,001 - \$150,000	\$150,001 - \$300,000	\$300,001 - \$500,000	\$500,001+ IS NEGOTIABLE	\$1 - \$50,000	\$50,001 - \$150,000	\$150,001 - \$300,000	\$300,001 - \$500,000	\$500,001+ IS NEGOTIABLE	\$1 - \$50,000	\$50,001 - \$150,000	\$150,001 - \$300,000	\$300,001 - \$500,000	\$500,001+ IS NEGOTIABLE					
5.5	Study Seating, Pedestal Base, Arm and Armless versions, Uph Seat & Back, Height Adjustable	KI Torsion (previously awarded)	53.9%	55.9%	55.9%	55.9%	55.9%						48.0%	50.0%	50.0%	50.0%	50.0%					
5.6	Study Seating, 4 Leg, All Wood, Armless and Arm versions	KI Crossroads 4 leg chair	52.9%	54.9%	54.9%	54.9%	54.9%						47.3%	49.3%	49.3%	49.3%	49.3%					
5.7	Study Seating, 4 Leg, Metal Frame, Arm and Armless versions, Upholstered, Wood or Poly Seat and Back	KI Versa (previously awarded)	53.9%	55.9%	55.9%	55.9%	55.9%						48.0%	50.0%	50.0%	50.0%	50.0%					
CLASSIFICATION 6: ACADEMIC ENVIRONMENTS/STUDENT LOUNGE PRODUCTS			Max Awards: 4					CATEGORY A: DROP SHIP DISCOUNT OFF LIST PRICE (MINIMUM)					CATEGORY B: DELIVERED & INSTALLED (MINIMUM DISCOUNT OFF LIST PRICE)					CATEGORY C: TURNKEY INSTALLATION (MINIMUM DISCOUNT OFF LIST PRICE)				
ITEM #	APPLICATION: Individual Lounge Product	VENDOR PRODUCT RECOMMENDATION:	TIER #1	TIER #2	TIER #3	TIER #4	TIER #5	TIER #1	TIER #2	TIER #3	TIER #4	TIER #5	TIER #1	TIER #2	TIER #3	TIER #4	TIER #5					
			\$1 - \$50,000	\$50,001 - \$150,000	\$150,001 - \$300,000	\$300,001 - \$500,000	\$500,001+ IS NEGOTIABLE	\$1 - \$50,000	\$50,001 - \$150,000	\$150,001 - \$300,000	\$300,001 - \$500,000	\$500,001+ IS NEGOTIABLE	\$1 - \$50,000	\$50,001 - \$150,000	\$150,001 - \$300,000	\$300,001 - \$500,000	\$500,001+ IS NEGOTIABLE					
6.1	Individual Club Chair Units, w/Tablet Arm Options	KI MyWay, Cody, Teacup, Relax, Jessa, Sela (previously awarded)	49.0%	51.0%	51.0%	51.0%	51.0%	43.1%	45.1%	45.1%	45.1%	45.1%	42.3%	44.3%	44.3%	44.3%	44.3%					
6.2	Individual Lounge Units, Available as Chair, Loveseat and Ottoman, Fully Upholstered, Mobile or Glide Foot, Cup Holder and Tablet Arm Options	KI MyWay, Cody, Lido, Jessa, Teacup, Sela (previously awarded)	51.5%	53.5%	53.5%	53.5%	53.5%	45.8%	47.8%	47.8%	47.8%	47.8%	45.2%	47.2%	47.2%	47.2%	47.2%					
6.3	Individual Lounge Units, Available in Single, Settee, and Sofa Configurations, Arm or Armless Options, w/Field Replaceable Upholstery, Tablet Arms and Caster Options.	KI MyWay, Cody, Lido, Grand Salon, Cinturon, Jessa, Mesa, Pomfret, Arissa (previously awarded)	51.5%	53.5%	53.5%	53.5%	53.5%	45.8%	47.8%	47.8%	47.8%	47.8%	45.2%	47.2%	47.2%	47.2%	47.2%					
6.4	Individual Bench, Available in Single, Double or Triple Lengths, Wood Frame, and Wood or Upholstered Options	KI Hancock, Neena, Three Bench (previously awarded)	51.5%	53.5%	53.5%	53.5%	53.5%	45.8%	47.8%	47.8%	47.8%	47.8%	45.2%	47.2%	47.2%	47.2%	47.2%					
6.5	Bench, Available in Single, Double or Triple Lengths, Steel Frame, Upholstered Seat	KI Kurv (previously awarded)	49.0%	51.0%	51.0%	51.0%	51.0%	43.1%	45.1%	45.1%	45.1%	45.1%	42.3%	44.3%	44.3%	44.3%	44.3%					
6.6	Occasional Table, Available in Square, Round, and Rectangular Shapes, 4 Leg, Wood Frame and Top,	KI Flex (previously awarded)	51.5%	53.5%	53.5%	53.5%	53.5%	45.8%	47.8%	47.8%	47.8%	47.8%	45.2%	47.2%	47.2%	47.2%	47.2%					
6.7	Occasional Table, Available in Square, Round, and Rectangular Shapes, 4 Leg, Metal Frame and Wood or Laminate Top, and Wood or PVC Edge Option	KI Rado (previously awarded)	51.5%	53.5%	53.5%	53.5%	53.5%	45.8%	47.8%	47.8%	47.8%	47.8%	45.2%	47.2%	47.2%	47.2%	47.2%					
CLASSIFICATION 6: ACADEMIC ENVIRONMENTS/STUDENT LOUNGE PRODUCTS			Max Awards: 4					CATEGORY A: DROP SHIP DISCOUNT OFF LIST PRICE (MINIMUM)					CATEGORY B: DELIVERED & INSTALLED (MINIMUM DISCOUNT OFF LIST PRICE)					CATEGORY C: TURNKEY INSTALLATION (MINIMUM DISCOUNT OFF LIST PRICE)				
ITEM #	APPLICATION: Modular Lounge Product	VENDOR PRODUCT RECOMMENDATION:	TIER #1	TIER #2	TIER #3	TIER #4	TIER #5	TIER #1	TIER #2	TIER #3	TIER #4	TIER #5	TIER #1	TIER #2	TIER #3	TIER #4	TIER #5					
			\$1 - \$50,000	\$50,001 - \$150,000	\$150,001 - \$300,000	\$300,001 - \$500,000	\$500,001+ IS NEGOTIABLE	\$1 - \$50,000	\$50,001 - \$150,000	\$150,001 - \$300,000	\$300,001 - \$500,000	\$500,001+ IS NEGOTIABLE	\$1 - \$50,000	\$50,001 - \$150,000	\$150,001 - \$300,000	\$300,001 - \$500,000	\$500,001+ IS NEGOTIABLE					
6.8	Modular Lounge Units, Upholstered, Available in Single, Settee and Bench sizes; Curved and Straight Configurations, Wood or Metal Feet Options, Attached Table Options	Hub Modular Lounge System	51.5%	53.5%	53.5%	53.5%	53.5%	45.8%	47.8%	47.8%	47.8%	47.8%	45.2%	47.2%	47.2%	47.2%	47.2%					
6.9	Modular Lounge Units, Available in Sofa, Bench and Ottoman Configurations, with Ganging, Floor Mounting, Back or Backless Options, Table Options	Hub Modular Lounge System	51.5%	53.5%	53.5%	53.5%	53.5%	45.8%	47.8%	47.8%	47.8%	47.8%	45.2%	47.2%	47.2%	47.2%	47.2%					
6.10	Modular Lounge Units, Waiting Area Seating, Leg-Based, Ganging, Poly Seat & Back, Arms or Armless Versions	KI Torsion Tandem, Dorsal Tandem (previously awarded)	52.8%	54.8%	54.8%	54.8%	54.8%	47.3%	49.3%	49.3%	49.3%	49.3%	46.7%	48.7%	48.7%	48.7%	48.7%					
6.11	Modular Lounge Units, Waiting Area Ganging Seating, Beam Mounted, with Table Options, Upholstered Seat & Back, Arms or Armless	KI Torsion Tandem, Dorsal Tandem (previously awarded)	52.8%	54.8%	54.8%	54.8%	54.8%	47.3%	49.3%	49.3%	49.3%	49.3%	46.7%	48.7%	48.7%	48.7%	48.7%					
CLASSIFICATION 7: ACADEMIC ENVIRONMENTS/ STANDARD LIBRARY FURNITURE			Max Awards: 3					CATEGORY A: DROP SHIP DISCOUNT OFF LIST PRICE (MINIMUM)					CATEGORY B: DELIVERED & INSTALLED (MINIMUM DISCOUNT OFF LIST PRICE)					CATEGORY C: TURNKEY INSTALLATION (MINIMUM DISCOUNT OFF LIST PRICE)				
ITEM #	APPLICATION: Student Study Carrels & Tables	VENDOR PRODUCT RECOMMENDATION:	TIER #1	TIER #2	TIER #3	TIER #4	TIER #5	TIER #1	TIER #2	TIER #3	TIER #4	TIER #5	TIER #1	TIER #2	TIER #3	TIER #4	TIER #5					
			\$1 - \$50,000	\$50,001 - \$150,000	\$150,001 - \$300,000	\$300,001 - \$500,000	\$500,001+ IS NEGOTIABLE	\$1 - \$50,000	\$50,001 - \$150,000	\$150,001 - \$300,000	\$300,001 - \$500,000	\$500,001+ IS NEGOTIABLE	\$1 - \$50,000	\$50,001 - \$150,000	\$150,001 - \$300,000	\$300,001 - \$500,000	\$500,001+ IS NEGOTIABLE					
7.1	Modular Study Carrel Units, with Wood and/or Laminate Surface options, Divider Options, Power & Data options, Wood Base	KI Crossroads (previously awarded)	52.9%	54.9%	54.9%	54.9%	54.9%						47.3%	49.3%	49.3%	49.3%	49.3%					

**EXHIBIT B:
PRICE SHEET DISCOUNT OFF LIST, AS OF 4/7/2015**

7.2	Modular Study Tables, with Wood and/or Laminate Surface options, Fixed Height, Power & Data options, Wood and/or Metal Base options	Backbone	51.5%	53.5%	53.5%	53.5%	53.5%								45.2%	47.2%	47.2%	47.2%	47.2%
7.3	Modular Computer Study Tables, with Wood and/or Laminate Surface options, Fixed Height, Divider Options, Power & Data options, Wood and/or Metal Base options	Backbone	51.5%	53.5%	53.5%	53.5%	53.5%								45.2%	47.2%	47.2%	47.2%	47.2%
ITEM #	APPLICATION: Seating Products	VENDOR PRODUCT RECOMMENDATION:	TIER #1 \$1 - \$50,000	TIER #2 \$50,001 - \$150,000	TIER #3 \$150,001 - \$300,000	TIER #4 \$300,001 - \$500,000	TIER #5 \$500,001+ IS NEGOTIABLE	TIER #1 \$1 - \$50,000	TIER #2 \$50,001 - \$150,000	TIER #3 \$150,001 - \$300,000	TIER #4 \$300,001 - \$500,000	TIER #5 \$500,001+ IS NEGOTIABLE	TIER #1 \$1 - \$50,000	TIER #2 \$50,001 - \$150,000	TIER #3 \$150,001 - \$300,000	TIER #4 \$300,001 - \$500,000	TIER #5 \$500,001+ IS NEGOTIABLE		
7.4	Wood Reading Table Seating, Arm and Armless versions, All Wood or Upholstered Seat options	KI Crossroads, Xylon (previously awarded)	51.5%	53.5%	53.5%	53.5%	53.5%	45.8%	47.8%	47.8%	47.8%	47.8%	45.2%	47.2%	47.2%	47.2%	47.2%		
7.5	Reading Table Seating, Metal Frame, Upholstered, Wood or Poly Seat and Back options, 4 Leg Base, With and Without Arms	KI Versa (previously awarded)	53.9%	55.9%	55.9%	55.9%	55.9%	48.6%	50.6%	50.6%	50.6%	50.6%	48.0%	50.0%	50.0%	50.0%	50.0%		
7.6	Individual Lounge Units, Upholstered, Available in range of sizes and configurations, Wood or Metal Feet Options, Attached Table Options	KI MyWay Lounge, Cody Lounge, Lido Lounge, Jessa Lounge (previously awarded)	51.5%	53.5%	53.5%	53.5%	53.5%	45.8%	47.8%	47.8%	47.8%	47.8%	45.2%	47.2%	47.2%	47.2%	47.2%		
CLASSIFICATION 9: ADMINISTRATIVE ENVIRONMENTS/OFFICE ENVIRONMENTS			Max Awards: 3	CATEGORY A: DROP SHIP DISCOUNT OFF LIST PRICE (MINIMUM)					CATEGORY B: DELIVERED & INSTALLED (MINIMUM DISCOUNT OFF LIST PRICE)					CATEGORY C: TURNKEY INSTALLATION DISCOUNT OFF LIST PRICE (MINIMUM)					
ITEM #	APPLICATION: Office Seating	VENDOR PRODUCT RECOMMENDATION:	TIER #1 \$1 - \$50,000	TIER #2 \$50,001 - \$150,000	TIER #3 \$150,001 - \$300,000	TIER #4 \$300,001 - \$500,000	TIER #5 \$500,001+ IS NEGOTIABLE	TIER #1 \$1 - \$50,000	TIER #2 \$50,001 - \$150,000	TIER #3 \$150,001 - \$300,000	TIER #4 \$300,001 - \$500,000	TIER #5 \$500,001+ IS NEGOTIABLE	TIER #1 \$1 - \$50,000	TIER #2 \$50,001 - \$150,000	TIER #3 \$150,001 - \$300,000	TIER #4 \$300,001 - \$500,000	TIER #5 \$500,001+ IS NEGOTIABLE		
9.1	Short Term Task Seating, Arm or Armless versions, Height Adjustable, Pedestal Base, Uph. Seat, Uph. and/or Poly Seat Options, Casters	Piretti Grazie Collection, Piretti Torsion Air Collection	51.5%	53.5%	53.5%	53.5%	53.5%	47.8%	47.8%	47.8%	47.8%	47.8%	45.2%	47.2%	47.2%	47.2%	47.2%		
9.2	Short Term Task Seating, Arm or Armless versions, Height Adjustable, Pedestal Base, Uph. Seat and Back, Casters	KI Torsion, Strive, Impress, Glimmer, Kismet, Allude, Pilot (previously awarded), Sift Seating	51.5%	53.5%	53.5%	53.5%	53.5%	47.8%	47.8%	47.8%	47.8%	47.8%	45.2%	47.2%	47.2%	47.2%	47.2%		
9.3	Long Term Task Seating, Arm or Armless versions, Height Adjustable, Pedestal Base, Uph. Seat and Back, Casters	KI Engage, Impress, Impress Ultra, Kismet, Allude, Pilot, ALTUS (previously awarded), Sift Seating	51.5%	53.5%	53.5%	53.5%	53.5%	47.8%	47.8%	47.8%	47.8%	47.8%	45.2%	47.2%	47.2%	47.2%	47.2%		
9.4	Guest Seating, 4 Leg, Steel Frame, Arm and Armless versions, Upholstered Seat and Back, Poly Shell Option	Piretti Grazie Collection, Piretti Torsion Air Collection, Sift Seating	51.5%	53.5%	53.5%	53.5%	53.5%	47.8%	47.8%	47.8%	47.8%	47.8%	45.2%	47.2%	47.2%	47.2%	47.2%		
9.5	Guest Seating, 4 Leg, Wood Frame, Arm and Armless versions, Upholstered Seat and Back, Wood Back Option	KI Aston, Bantam, Canaan, Pomfret, Quattro, Aerdyn, Xylon (previously awarded)	51.5%	53.5%	53.5%	53.5%	53.5%	47.8%	47.8%	47.8%	47.8%	47.8%	45.2%	47.2%	47.2%	47.2%	47.2%		
ITEM #	APPLICATION: Office Storage	VENDOR PRODUCT RECOMMENDATION:	TIER #1 \$1 - \$50,000	TIER #2 \$50,001 - \$150,000	TIER #3 \$150,001 - \$300,000	TIER #4 \$300,001 - \$500,000	TIER #5 \$500,001+ IS NEGOTIABLE	TIER #1 \$1 - \$50,000	TIER #2 \$50,001 - \$150,000	TIER #3 \$150,001 - \$300,000	TIER #4 \$300,001 - \$500,000	TIER #5 \$500,001+ IS NEGOTIABLE	TIER #1 \$1 - \$50,000	TIER #2 \$50,001 - \$150,000	TIER #3 \$150,001 - \$300,000	TIER #4 \$300,001 - \$500,000	TIER #5 \$500,001+ IS NEGOTIABLE		
9.6	Lateral Files, Storage Units and Wardrobe Cabinets, Steel, Locking	KI 700 Series, U Series (previously awarded), Connection Zone (Benching, Storage, Screens and Dividers)	52.3%	54.3%	54.3%	54.3%	54.3%						46.1%	48.1%	48.1%	48.1%	48.1%		
9.7	Bookcases, 2 to 7 High, w/Adjustable Shelves, Steel	KI 700 Series (previously awarded)	54.5%	56.5%	56.5%	56.5%	56.5%						48.6%	50.6%	50.6%	50.6%	50.6%		
9.8	Vertical Files, 2 to 5 High, Steel, Locking	KI Vertical Files (previously awarded)	52.3%	54.3%	54.3%	54.3%	54.3%						46.1%	48.1%	48.1%	48.1%	48.1%		
9.9	Pedestals, Mobile w/ Top or Fixed, Range of Depths, Drawer Pull Options and Configurations, Steel, Locking	KI 700 Series (previously awarded)	56.6%	58.6%	58.6%	58.6%	58.6%						51.0%	53.0%	53.0%	53.0%	53.0%		
9.10	Paper Management System, Rail or Desk Supported, Range of Configurations, Steel or Plastic	KI StudioWorks Accessories, Wireworks Accessories (previously awarded)	54.5%	56.5%	56.5%	56.5%	56.5%						48.6%	50.6%	50.6%	50.6%	50.6%		
ITEM #	APPLICATION: Freestanding Tables & Desks	VENDOR PRODUCT RECOMMENDATION:	TIER #1 \$1 - \$50,000	TIER #2 \$50,001 - \$150,000	TIER #3 \$150,001 - \$300,000	TIER #4 \$300,001 - \$500,000	TIER #5 \$500,001+ IS NEGOTIABLE	TIER #1 \$1 - \$50,000	TIER #2 \$50,001 - \$150,000	TIER #3 \$150,001 - \$300,000	TIER #4 \$300,001 - \$500,000	TIER #5 \$500,001+ IS NEGOTIABLE	TIER #1 \$1 - \$50,000	TIER #2 \$50,001 - \$150,000	TIER #3 \$150,001 - \$300,000	TIER #4 \$300,001 - \$500,000	TIER #5 \$500,001+ IS NEGOTIABLE		
9.11	Meeting or Break Room Tables, Square, Rectangular or Round Shapes, Range of Sizes, PVC Edge, Fixed and Folding Base Options, Laminate/Steel	WorkUp, Toggle, KI Pirouette, Trek, Barron, DataLink MP, Venue, Trek (previously awarded), Connection Zone (Benching, Storage, Screens and Dividers)	53.9%	55.9%	55.9%	55.9%	55.9%						48.0%	50.0%	50.0%	50.0%	50.0%		

**EXHIBIT B:
PRICE SHEET DISCOUNT OFF LIST, AS OF 4/7/2015**

9.12	Meeting Room Tables, Square, Rectangular or Round Shapes, Range of Sizes, Wood Edge, Metal Base, Power/Data Options, Laminate or Wood Top	KI Pirouette, Venue, Trek, Synthesis (previously awarded)	51.5%	53.5%	53.5%	53.5%	53.5%								45.2%	47.2%	47.2%	47.2%	47.2%
9.13	Wood Frame Desk Series, Fixed Height, with Desk, Credenza, Hutch, and Pedestal Storage Options	KI Darwin, Delsanti, DaVinci, True Desking, Aristotle (previously awarded)	51.5%	53.5%	53.5%	53.5%	53.5%								45.2%	47.2%	47.2%	47.2%	47.2%
9.14	Metal Frame Desk Series, Fixed Height, with Desk, Credenza, Hutch, and Pedestal Storage Options/ Laminate Top with Wood or PVC Edge	KI 700 Series, True Desking (previously awarded)	54.5%	56.5%	56.5%	56.5%	56.5%								48.6%	50.6%	50.6%	50.6%	50.6%
ITEM #	APPLICATION: Systems	VENDOR PRODUCT RECOMMENDATION:	TIER #1 \$1 - \$50,000	TIER #2 \$50,001 - \$150,000	TIER #3 \$150,001 - \$300,000	TIER #4 \$300,001 - \$500,000	TIER #5 \$500,001+ IS NEGOTIABLE	TIER #1 \$1 - \$50,000	TIER #2 \$50,001 - \$150,000	TIER #3 \$150,001 - \$300,000	TIER #4 \$300,001 - \$500,000	TIER #5 \$500,001+ IS NEGOTIABLE	TIER #1 \$1 - \$50,000	TIER #2 \$50,001 - \$150,000	TIER #3 \$150,001 - \$300,000	TIER #4 \$300,001 - \$500,000	TIER #5 \$500,001+ IS NEGOTIABLE		
9.15	Stackable Panel System, with Range of Heights, Elements, Surface and Component Options, 8-Wire Electrical System	Unite System	52.3%	54.3%	54.3%	54.3%	54.3%								46.1%	48.1%	48.1%	48.1%	48.1%
9.16	Monolithic Panel System, with Range of Heights, Surface and Component Options, 8-Wire Electrical System	Unite System, Trellis System	52.3%	54.3%	54.3%	54.3%	54.3%								46.1%	48.1%	48.1%	48.1%	48.1%
9.17	Benching Desk System, with Range of Divider Heights, Surface and Component Options, 8-Wire Electrical System	Unite System	52.3%	54.3%	54.3%	54.3%	54.3%								46.1%	48.1%	48.1%	48.1%	48.1%
9.18	Desking System, with Range of Divider Heights, Adjustable Worksurface, Surface and Component Options, 8-Wire Electrical System	Unite System	52.3%	54.3%	54.3%	54.3%	54.3%								46.1%	48.1%	48.1%	48.1%	48.1%
ITEM #	APPLICATION: Technology Tools	VENDOR PRODUCT RECOMMENDATION:	TIER #1 \$1 - \$50,000	TIER #2 \$50,001 - \$150,000	TIER #3 \$150,001 - \$300,000	TIER #4 \$300,001 - \$500,000	TIER #5 \$500,001+ IS NEGOTIABLE	TIER #1 \$1 - \$50,000	TIER #2 \$50,001 - \$150,000	TIER #3 \$150,001 - \$300,000	TIER #4 \$300,001 - \$500,000	TIER #5 \$500,001+ IS NEGOTIABLE	TIER #1 \$1 - \$50,000	TIER #2 \$50,001 - \$150,000	TIER #3 \$150,001 - \$300,000	TIER #4 \$300,001 - \$500,000	TIER #5 \$500,001+ IS NEGOTIABLE		
9.19	Adjustable Keyboard Tray w/Non-Handed Mouse Tray	KI Keyboard Tray (previously awarded)	52.3%	54.3%	54.3%	54.3%	54.3%	46.7%	48.7%	48.7%	48.7%	48.7%	46.1%	48.1%	48.1%	48.1%	48.1%		
9.20	Adjustable Monitor Arm, Single or Dual, VESA Compliant	KI Monitor Arms (previously awarded)	52.3%	54.3%	54.3%	54.3%	54.3%	46.7%	48.7%	48.7%	48.7%	48.7%	46.1%	48.1%	48.1%	48.1%	48.1%		
9.21	CPU Holder, Adjustable, Hanging, Single or Dual Capacity	KI CPU Holders, Single & Dual (previously awarded), Connection Zone (Mobile Screens & Privacy Booths)	52.3%	54.3%	54.3%	54.3%	54.3%	46.7%	48.7%	48.7%	48.7%	48.7%	46.1%	48.1%	48.1%	48.1%	48.1%		
CLASSIFICATION 11: PUBLIC AREA SEATING		Max Awards: 3	CATEGORY A: DROP SHIP DISCOUNT OFF LIST PRICE (MINIMUM)					CATEGORY B: DELIVERED & INSTALLED (MINIMUM DISCOUNT OFF LIST PRICE)					CATEGORY C: TURNKEY INSTALLATION (MINIMUM DISCOUNT OFF LIST PRICE)						
ITEM #	APPLICATION: Loose Public Seating	VENDOR PRODUCT RECOMMENDATION:	TIER #1 \$1 - \$50,000	TIER #2 \$50,001 - \$150,000	TIER #3 \$150,001 - \$300,000	TIER #4 \$300,001 - \$500,000	TIER #5 \$500,001+ IS NEGOTIABLE	TIER #1 \$1 - \$50,000	TIER #2 \$50,001 - \$150,000	TIER #3 \$150,001 - \$300,000	TIER #4 \$300,001 - \$500,000	TIER #5 \$500,001+ IS NEGOTIABLE	TIER #1 \$1 - \$50,000	TIER #2 \$50,001 - \$150,000	TIER #3 \$150,001 - \$300,000	TIER #4 \$300,001 - \$500,000	TIER #5 \$500,001+ IS NEGOTIABLE		
11.1	Breakroom Seating, Arm and Armless versions, Metal Frame, Sled or 4 Leg Base, Poly Seat & Back	KI Perry, Glimmer, Rapture, Strive (previously awarded)	51.5%	53.5%	53.5%	53.5%	53.5%	45.8%	47.8%	47.8%	47.8%	47.8%	45.2%	47.2%	47.2%	47.2%	47.2%		
11.2	Breakroom Stool, Arm and Armless versions, Metal Frame, 5 Star Base, Poly Shell	KI Dorsal, Torsion (previously awarded)	53.9%	55.9%	55.9%	55.9%	55.9%	48.6%	50.6%	50.6%	50.6%	50.6%	48.0%	50.0%	50.0%	50.0%	50.0%		
11.3	High Density Stacking Chair, Wire Frame, Arm and Armless versions, Poly Seat & Back	Op4	50.1%	52.1%	52.1%	52.1%	52.1%	44.3%	46.3%	46.3%	46.3%	46.3%	43.6%	45.6%	45.6%	45.6%	45.6%		
11.4	Faculty Dining Area Stacking Chair, Metal Frame, Arm and Armless versions, Poly and Upholstered Seat & Back Options	KI Torsion, Dorsal (previously awarded)	53.9%	55.9%	55.9%	55.9%	55.9%	48.6%	50.6%	50.6%	50.6%	50.6%	48.0%	50.0%	50.0%	50.0%	50.0%		
11.5	Auditorium Folding Chair, Steel Frame, Armless, w/Thick Upholstered Seat Pads, Uph. Back, Ganging Option	KI 734 Folding Chair	51.5%	53.5%	53.5%	53.5%	53.5%	45.8%	47.8%	47.8%	47.8%	47.8%	45.2%	47.2%	47.2%	47.2%	47.2%		
11.6	Public Meeting Audience Seating, Stackable, Arm and Armless versions, Poly Seat & Back	KI Torsion, Dorsal, Perry, Piretti (previously awarded)	53.9%	55.9%	55.9%	55.9%	55.9%	48.6%	50.6%	50.6%	50.6%	50.6%	48.0%	50.0%	50.0%	50.0%	50.0%		
11.7	Public Meeting Audience Seating, Stackable, Arm and Armless versions, Upholstered Seat & Back	KI Torsion, Dorsal, Perry, Piretti (previously awarded)	53.9%	55.9%	55.9%	55.9%	55.9%	48.6%	50.6%	50.6%	50.6%	50.6%	48.0%	50.0%	50.0%	50.0%	50.0%		
11.8	Meeting Room Seating, Metal Frame, 4 Leg, Arm and Armless versions, Stackable, Upholstered Seat & Back, Poly Shell Option	KI Torsion, Rapture, Glimmer, M16, Piretti, Versa, Dorsal, Xylon (previously awarded)	51.5%	53.5%	53.5%	53.5%	53.5%	45.8%	47.8%	47.8%	47.8%	47.8%	45.2%	47.2%	47.2%	47.2%	47.2%		
11.9	Meeting Room Seating, Wood or Metal Frame, 4 Leg, Arm and Armless versions, Wood Seat & Back	KI Torsion, Engage, Impress, Impress Ultra, Strive, Glimmer, Kismet, Allude, Cinturon, ALTUS (previously awarded)	51.5%	53.5%	53.5%	53.5%	53.5%	45.8%	47.8%	47.8%	47.8%	47.8%	45.2%	47.2%	47.2%	47.2%	47.2%		

**EXHIBIT B:
PRICE SHEET DISCOUNT OFF LIST, AS OF 4/7/2015**

CLASSIFICATION 12: FIXED SEATING		Max Awards: 3	CATEGORY A: DROP SHIP DISCOUNT OFF LIST PRICE (MINIMUM)					CATEGORY B: DELIVERED & INSTALLED (MINIMUM DISCOUNT OFF LIST PRICE)					CATEGORY C: TURNKEY INSTALLATION (MINIMUM DISCOUNT OFF LIST PRICE)				
ITEM #	APPLICATION: Lecture Halls	VENDOR PRODUCT RECOMMENDATION:	TIER #1 \$1 - \$50,000	TIER #2 \$50,001 - \$150,000	TIER #3 \$150,001 - \$300,000	TIER #4 \$300,001 - \$500,000	TIER #5 \$500,001+ IS NEGOTIABLE	TIER #1 \$1 - \$50,000	TIER #2 \$50,001 - \$150,000	TIER #3 \$150,001 - \$300,000	TIER #4 \$300,001 - \$500,000	TIER #5 \$500,001+ IS NEGOTIABLE	TIER #1 \$1 - \$50,000	TIER #2 \$50,001 - \$150,000	TIER #3 \$150,001 - \$300,000	TIER #4 \$300,001 - \$500,000	TIER #5 \$500,001+ IS NEGOTIABLE
12.1	Beam Mounted Seating, Floor Mounted, Tablet Arm Option, Straight and Curved Beam Option, Poly Shell	KI Sequence Seating with All Approved Seat Shells (previously awarded)	49.0%	51.0%	51.0%	51.0%	51.0%						38.0%	40.0%	40.0%	40.0%	40.0%
12.2	Theatre Seating with Arm, Flip Seat, Floor Mounted, Tablet Arm Option, Poly Shell with Uph Seat and Back, Straight or Curved Application	KI Lancaster, Concerto (previously awarded)	49.0%	51.0%	51.0%	51.0%	51.0%						38.0%	40.0%	40.0%	40.0%	40.0%
12.3	Combined Table and Swing Out Seating, Floor Mounted, Straight or Curved Application, Table-top Power/Data Option, Metal Frame, Laminated Top with PVC Edge	KI University Seating (previously awarded)	49.0%	51.0%	51.0%	51.0%	51.0%						38.0%	40.0%	40.0%	40.0%	40.0%
12.4	Table, Floor Mounted, Straight or Curved Application, Contiguous or Non-Contiguous Version, Table-top Power/Data Option, Modesty Panel Option, Metal Frame, Laminated Top with PVC Edge	KI University Seating (previously awarded)	49.0%	51.0%	51.0%	51.0%	51.0%						38.0%	40.0%	40.0%	40.0%	40.0%
12.5	Single Pedestal Mount Seat, Floor Mounted, Tablet Arm Option, Arm and Armless Versions, Poly or Uph, Seat Option	KI Fixed Seating with All Approved Seat Shells (previously awarded)	49.0%	51.0%	51.0%	51.0%	51.0%						38.0%	40.0%	40.0%	40.0%	40.0%
12.6	Jury Base Seating, Floor Mounted, Swivel, Arm and Armless Versions, Poly Shell with Uph Option	KI Jury Base with All Approved Seat Shells (previously awarded)	49.0%	51.0%	51.0%	51.0%	51.0%						38.0%	40.0%	40.0%	40.0%	40.0%
ITEM #	APPLICATION: Spectator Seating	VENDOR PRODUCT RECOMMENDATION:	TIER #1 \$1 - \$50,000	TIER #2 \$50,001 - \$150,000	TIER #3 \$150,001 - \$300,000	TIER #4 \$300,001 - \$500,000	TIER #5 \$500,001+ IS NEGOTIABLE	TIER #1 \$1 - \$50,000	TIER #2 \$50,001 - \$150,000	TIER #3 \$150,001 - \$300,000	TIER #4 \$300,001 - \$500,000	TIER #5 \$500,001+ IS NEGOTIABLE	TIER #1 \$1 - \$50,000	TIER #2 \$50,001 - \$150,000	TIER #3 \$150,001 - \$300,000	TIER #4 \$300,001 - \$500,000	TIER #5 \$500,001+ IS NEGOTIABLE
12.7	Spectator Seating, Armless Version, Straight or Curved Application, Floor or Side Mounted, Indoor and Outdoor Application, Poly Seat and Back	HI5 Spectator Seating	49.0%	51.0%	51.0%	51.0%	51.0%						38.0%	40.0%	40.0%	40.0%	40.0%
CLASSIFICATION 13: WALL SYSTEMS		Max Awards: 2	CATEGORY A: DROP SHIP DISCOUNT OFF LIST PRICE (MINIMUM)					CATEGORY B: DELIVERED & INSTALLED (MINIMUM DISCOUNT OFF LIST PRICE)					CATEGORY C: TURNKEY INSTALLATION (MINIMUM DISCOUNT OFF LIST PRICE)				
ITEM #	APPLICATION: Walls	VENDOR PRODUCT RECOMMENDATION:	TIER #1 \$1 - \$50,000	TIER #2 \$50,001 - \$150,000	TIER #3 \$150,001 - \$300,000	TIER #4 \$300,001 - \$500,000	TIER #5 \$500,001+ IS NEGOTIABLE	TIER #1 \$1 - \$50,000	TIER #2 \$50,001 - \$150,000	TIER #3 \$150,001 - \$300,000	TIER #4 \$300,001 - \$500,000	TIER #5 \$500,001+ IS NEGOTIABLE	TIER #1 \$1 - \$50,000	TIER #2 \$50,001 - \$150,000	TIER #3 \$150,001 - \$300,000	TIER #4 \$300,001 - \$500,000	TIER #5 \$500,001+ IS NEGOTIABLE
13.1	Movable, Demountable Wall, Metal Frame, No Gypsum, Solid, Glass, Doors, Power and Data Options, Wood Veneer and Powdercoat Frame Options	KI Genius Wall	49.0%	51.0%	51.0%	51.0%	51.0%						28.7%	30.7%	30.7%	30.7%	30.7%
13.2	Storefront Wall System, Utilized Metal Frame, Glass, Doors, Power and Data Options, Powdercoat Frame	KI Lightline	49.0%	51.0%	51.0%	51.0%	51.0%						28.7%	30.7%	30.7%	30.7%	30.7%



FOUNDATION *for* CALIFORNIA
COMMUNITY COLLEGES

Furniture and Fixtures Applications CB13-013

Exhibit C: Additional Services and Capabilities

(RFP 13-002, Vendor Response, Exhibit D1: California Only; and D2: National – if applicable)

EXHIBIT D1
Pages 34 through 37

RFP #13-002
FURNITURE and FIXTURES APPLICATIONS

Additional Services and Capabilities For California Agencies

The Vendor should quote prices as requested for the list of services on a "Per Project" basis. These *additional* services are not part of the mandatory scope for pricing of the products shown in Exhibit B.

Request	Justification	Vendor's Response/Cost
1. Provide after-hours installation services (typical day defined as 8:00 AM to 5:00 PM, Monday to Friday) for Monday through Friday, Saturday or Sunday. Quote cost differential only for CA Participating Agencies in Column at right.	Allows for pre-determined costs for additional expenses chargeable to project or contractor.	Maximum \$ <u>25.00</u> /Hr above included costs for California Clients
2. Provide Prevailing Wage rate for Installation Labor when required by project due to funding sources. Quote cost differential only for CA Participating Agencies in Column at right.	In specifically identified projects where law and/or local policy requires payment of Prevailing Wage, ensures that budgeting can readily be incorporated into the process.	Maximum \$ <u>36.00</u> /Hr above included costs for California Clients (if Prevailing Wage rates vary by locale, attach separate sheet with current rates by location).
3. Provide labor rate for additional services not included in the defined scope of Exhibit A, such as "walk-up" of products above the first floor due to lack of elevator access, double handling, etc. due to unforeseen site conditions. Quote hourly rate only for CA Participating Agencies in Column at right.	In specific situations where <i>unforeseen site conditions</i> require additional labor, ensures that budgeting can readily be incorporated into the process.	Maximum \$ <u>54.00</u> /Hr above included costs for California Clients (if rates vary by trade, attach separate sheet with breakdown of maximum upcharge).
4. Provide labor rates for additional services not included in the defined scope of Exhibit A, such as reconfiguration of existing product, relocation of existing products, etc. Quote hourly rate only for CA Participating Agencies in Column at right.	In specific situation where Participating Agency wishes to incorporate existing product by vendor, ensures contractual capability to invoice for services.	Maximum \$ <u>54.00</u> /Hr above included costs for California Clients (if rates vary by trade, attach separate sheet with breakdown of maximum upcharge).

<p>5. Provide Engineering Calculations for applicable products necessary to satisfy state local code requirements required by project scope. Quote hourly rate only for CA Participating Agencies in Column at right.</p>	<p>In specifically identified projects where code or project requirements demand structural engineering calculations, ensures that budgeting can readily be incorporated into the process.</p>	<p>Maximum \$ <u>86.00</u>/Hr for California Clients.</p>
<p>6. Provide costs for storage of Vendor products should Participating Agency site not be available for receipt of product as confirmed, beyond first thirty (30) days to be covered by Vendor. Quote square footage rate only for CA Participating Agencies in Column at right.</p>	<p>Provides contractual capability for Vendor to be reimbursed by Participating Agency should site conditions require storage of shipped items.</p>	<p>Maximum \$ ___/square foot beyond 30 days for California Clients \$0.53 per cubic foot</p>
<p>7. Indicate if your company is capable of providing electronic transmittal of all order documentations in Adobe Reader format to the Participating Agencies including PO acceptance, acknowledgement issuance and invoicing. Indicate Yes or No in the column at right.</p>	<p>Minimizes handling of paperwork and documentation, saving the Participating Agency money; reduces the amount of time needed to get the project moving and completed.</p>	<p>Yes <u> X </u> No _____</p>
<p>8. Indicate if your company is willing to comply with the following: The Vendor may provide products that do not have a two (2) year track record within the Community College environment only if those Vendors agree to the following:</p> <p>a) Vendor will replace at no charge with a product of equal or better value those items that do not meet the Performance Requirements required by this RFP within a one (1) year period from the date of installation. After one (1) year, contract warranties as described in this RFP for all other products remain in place.</p> <p>Indicate Yes or No in the column at right.</p>	<p>Community Colleges are not a good test market for new products. Colleges need to know that they are getting a proven, quality product.</p> <p>This section allows for Vendors who stand behind new products introduced to the marketplace to provide their latest offerings.</p>	<p>Yes <u> X </u> No _____</p>

<p>9. Indicate if your firm agrees in advance to offer additional, appropriate products beyond the products defined in Exhibit B at a pre-defined discount.</p> <p>Quote Minimum Discounts per Pricing Category in column at right.</p>	<p>Provides Participating Agencies with pre-determined minimum discounting for additional items.</p>	<p>Minimum Discount Off List, Inclusive of Exhibit A Services: Category A: <u>51.50%</u> Category B: <u>46.50%</u> Category C: <u>46.20%</u></p>
<p>10. Provide specifics regarding support services that are factory certified, for both pre-order and implementation requirements of an order. Provide an additional written response to this question: Describe how these support teams have been specifically involved in similar scopes of work requirements.</p> <ul style="list-style-type: none"> o What is the range of service expectations required by current Vendor or Dealer held purchasing vehicles? o How are these individuals or teams directly involved in the pre-sales and post-sales process? o What training did you offer these teams in order to be more successful over time? 	<p>Assures the Participating Agency that their need to support "local" businesses can be met through this contract.</p>	<p>Qty of Authorized Dealers in CA: <u>18</u></p> <p>Qty of Authorized, Third Party Installation Firms in CA: <u>7</u></p> <p>Number of Factory Support Staff dedicated to CA: <u>40</u></p> <p>Attach separate document labeled Exhibit D1 Item 10.</p>
<p>11. Provide a written response to this question: Vendors, describe your direct experience with a California Higher Education institution (preferably a community college) that was undergoing a Capital Improvement Program.</p> <ul style="list-style-type: none"> o What was the scope of your work for the project? o What were the specific challenges that you faced? o How did you overcome those challenges? o What would you do differently next time to help address the issues proactively? o How have you used this specific experience to improve your internal processes and client interactions? 	<p>Assures the Participating Agencies that the Vendor and their team have a solid working knowledge of the realities of this environment.</p>	<p>Attach separate document labeled Exhibit D1 Item 11.</p> <p>Included in Exhibit D1</p>

<p>12. Would your firm agree in advance to consolidate an Agency's orders that will ship over a one (1) year period of time, to apply the deepest discount applicable, regardless of individual PO value, to <u>all orders</u>, based upon an intention to procure a specific volume of product and services utilizing this contract?</p> <p>Indicate <u>Yes</u> or <u>No</u> in the column at right.</p>	<p>Recognizes and rewards enterprise-level partnerships between Vendors and agencies, increasing value to the organizations, and allows for Participating Agencies to stabilize project budgeting over a longer period of time.</p>	<p>Yes <u> X </u></p> <p>No <u> </u></p>
<p>13. Would your firm offer Participating Agency increased flexibility beyond the 12 week notification of site readiness required in Exhibit A, Criterion B.5 without incurring penalties?</p> <p>Indicate <u>Yes</u> or <u>No</u> in the column at right, and note additional time allowed in weeks.</p>	<p>Recognizes and rewards enterprise-level partnerships between Vendors and agencies, increasing value to the organizations, and allows for Participating Agencies to address project issues and budgets as they arise without requiring additional board approval.</p>	<p>Yes <u> X </u></p> <p>No <u> </u></p> <p>Number of weeks allowed prior to scheduled delivery? <u> 4 </u></p> <p>Special "custom" made product would not be included.</p>
<p>14. Would your firm agree to participate in the Scholarship Endowment Contribution for National Orders as described in Section I: Item 7? California orders only</p> <p>Indicate <u>Yes</u> or <u>No</u> in the column at right.</p>	<p>Reflects the vendor's corporate commitment to the ongoing success of California's Community College Students.</p>	<p>Yes <u> X on California orders </u></p> <p>No <u> </u></p>

I have read and understood the expectations defined in Exhibit D1: Additional Services and Capabilities For California Agencies.

Name: 
Vendor: Krueger International, Inc.

Title: Assistant Secretary
Date: 9/13/13



**FOUNDATION for CALIFORNIA
COMMUNITY COLLEGES**

*Benefiting, Supporting, and Enhancing
the California Community Colleges*

1102 Q Street, Third Floor
Sacramento, California 95811-6549
Toll-Free Telephone: 866.325.3222
Facsimile: 916.325.0844

www.foundationccc.org

Lee Amundson
Krueger International (KI)
1330 Bellevue Street
P.O. Box 8100
Green Bay, WI 54308

August 28, 2014

Dear Ms. Amundson,

RE: Product Addition Request for CollegeBuys, Contract #CB13-013

This letter is to inform you that Krueger International (KI)'s Product Addition Request for the product lines noted below has been approved, and may be procured by participating agencies at the same level of discounting in Exhibit B: Pricing and Product Information in **Contract #CB13-013** as indicated for the specific items below, per Item 13 of the General Provisions section of the agreement:

CB #13-013 Exhibit B: Product and Pricing Information			
Product Line	Classification	Application	Item(s)
MyWay Lounge	6 - Academic Environments/Student Lounge Products	Individual Lounge	6.1, 6.2, and 6.3
MyWay Lounge	7 - Academic Environments/Standard Library Furniture	Seating Products	7.6
Pirouette Tables	9 - Administrative Environments/Office Environments	Freestanding Tables & Desks	9.11 and 9.12

KI shall honor the enhanced warranty requirements outlined in Exhibit A: Mandatory Performance and Service Specifications for these approved product lines. The discounting levels shall apply as of the date indicated in this communication (Effective Date). Product addition information will be made available on the Foundation website.

In an effort to ensure that these product additions are communicated effectively, the Foundation recommends that KI:

- Communicate these product additions to all entities currently utilizing the contract.
- Communicate the acceptance of these product additions to **Contract #CB13-013** to all participating agencies within thirty (30) days of approval.

(Continued on next page)

If you have any questions or concerns please feel free to contact me directly. And thank you for your on-going support of our Community Colleges.

Sincerely,

A handwritten signature in black ink, appearing to read "Jorge J.C. Sales". The signature is stylized with large, sweeping letters and a prominent flourish at the end.

Jorge J.C. Sales
Director of CollegeBuys
jsales@foundationccc.org
916-425-8575



**FOUNDATION for CALIFORNIA
COMMUNITY COLLEGES**

*Benefiting, Supporting, and Enhancing
the California Community Colleges*

1102 Q Street, Suite 3500
Sacramento, California 95811-6549
Toll-Free Telephone: 866.325.3222
Facsimile: 916.325.0844

www.foundationccc.org

Lee Amundson
Krueger International (KI)
1330 Bellevue Street
P.O. Box 8100
Green Bay, WI 54308

November 13, 2014

Dear Ms. Amundson,

RE: Product Additions Request for CollegeBuys, Contract #CB13-013

This letter is to inform you that Krueger International (KI)'s Product Addition Request for the product lines noted below has been approved, and may be procured by participating agencies at the same level of discounting in Exhibit B: Pricing and Product Information in **Contract #CB13-013** as indicated for the specific items below, per Item 13 of the General Provisions section of the agreement:

CB#13-013 Exhibit B: Product and Pricing Information			
Product Line	Classification	Application	Item(s)
Sift Seating (Task and Guest)	9: Administrative and Environments/Office Environments	Office Seating	9.2, 9.3 & 9.4

KI shall honor the enhanced warranty requirements outlined in Exhibit A: Mandatory Performance and Service Specifications for these approved product lines. The discounting levels shall apply as of the date indicated in this communication (Effective Date). Product addition information will be made available on the Foundation website.

In an effort to ensure that these product additions are communicated effectively, the Foundation recommends that KI:

- Communicate these product additions to all entities currently utilizing the contract.
- Communicate the acceptance of these product additions to **Contract #CB13-013** to all participating agencies within thirty (30) days of approval.

(Continued on next page)



FOUNDATION *for* CALIFORNIA
COMMUNITY COLLEGES

*Benefiting, Supporting, and Enhancing
the California Community Colleges*

1102 Q Street, Suite 3500
Sacramento, California 95811-6549
Toll-Free Telephone: 866.325.3222
Facsimile: 916.325.0844

www.foundationccc.org

If you have any questions or concerns please feel free to contact me directly. And thank you for your on-going support of our Community Colleges.

Sincerely,

Jorge J.C. Sales
Director of CollegeBuys
jsales@foundationccc.org
916-425-8575

(Continued on next page)



**FOUNDATION for CALIFORNIA
COMMUNITY COLLEGES**

*Benefiting, Supporting, and Enhancing
the California Community Colleges*

1102 Q Street, Suite 3500
Sacramento, California 95811-6549
Toll-Free Telephone: 866.325.3222
Facsimile: 916.325.0844
www.foundationccc.org

Lee Amundson
Krueger International (KI)
1330 Bellevue Street
P.O. Box 8100
Green Bay, WI 54308

December 22, 2014

Dear Ms. Amundson,

RE: Product Addition Request for CollegeBuys, Contract #CB13-013

This letter is to inform you that Krueger International (KI)'s Product Addition Request for the product lines noted below has been approved, and may be procured by participating agencies at the same level of discounting in Exhibit B: Pricing and Product Information in **Contract #CB13-013** as indicated for the specific items below, per Item 13 of the General Provisions section of the agreement:

CB #13-013 Exhibit B: Product and Pricing Information			
Product Line	Classification	Application	Item(s)
Toggle	5 – Academic Environments/Study Areas 9 – Freestanding Tables and Desks	Study Area Tables / Freestanding Tables & Desks	5.2 and 9.11
WorkUp	5 – Academic Environments/Study Areas 9 – Freestanding Tables and Desks	Study Area Tables / Freestanding Tables & Desks	5.2 and 9.11

KI shall honor the enhanced warranty requirements outlined in Exhibit A: Mandatory Performance and Service Specifications for these approved product lines. The discounting levels shall apply as of the date indicated in this communication (Effective Date). Product addition information will be made available on the Foundation website.

In an effort to ensure that these product additions are communicated effectively, the Foundation recommends that KI:

- Communicate these product additions to all entities currently utilizing the contract.
- Communicate the acceptance of these product additions to **Contract #CB13-013** to all participating agencies within thirty (30) days of approval.

(Continued on next page)



FOUNDATION *for* CALIFORNIA
COMMUNITY COLLEGES

*Benefiting, Supporting, and Enhancing
the California Community Colleges*

1102 Q Street, Suite 3500
Sacramento, California 95811-6549
Toll-Free Telephone: 866.325.3222
Facsimile: 916.325.0844

www.foundationccc.org

If you have any questions or concerns please feel free to contact me directly. And thank you for your on-going support of our Community Colleges.

Sincerely,

Jorge J.C. Sales
Director of CollegeBuys
jsales@foundationccc.org
916-425-8575



Lee Amundson
Krueger International (KI)
1330 Bellevue Street
P.O. Box 8100
Green Bay, WI 54308

January 27, 2015

Dear Ms. Amundson,

RE: Product Addition Request for CollegeBuys, Contract #CB13-013

This letter is to inform you that Krueger International (KI)'s Product Addition Request for the product line noted below has been approved, and may be procured by participating agencies at the same level of discounting in Exhibit B: Pricing and Product Information in **Contract #CB13-013** as indicated for the specific items below, per Item 13 of the General Provisions section of the agreement:

CB #13-013 Exhibit B: Product and Pricing Information			
Product Line	Classification	Application	Item
Trellis System	9 - ADMINISTRATIVE ENVIRONMENTS/OFFICE ENVIRONMENTS	Systems	9.16

KI shall honor the enhanced warranty requirements outlined in Exhibit A: Mandatory Performance and Service Specifications for these approved product lines. The discounting levels shall apply as of the date indicated in this communication (Effective Date). Product addition information will be made available on the Foundation website.

In an effort to ensure that these product additions are communicated effectively, the Foundation recommends that KI:

- Communicate these product additions to all entities currently utilizing the contract.
- Communicate the acceptance of these product additions to **Contract #CB13-013** to all participating agencies within thirty (30) days of approval.



FOUNDATION *for* CALIFORNIA
COMMUNITY COLLEGES

*Benefiting, Supporting, and Enhancing
the California Community Colleges*

1102 Q Street, Suite 3500
Sacramento, California 95811-6549
Toll-Free Telephone: 866.325.3222
Facsimile: 916.325.0844

www.foundationccc.org

If you have any questions or concerns please feel free to contact me directly. And thank you for your on-going support of our Community Colleges.

Sincerely,

Jorge J.C. Sales
Director of CollegeBuys
jsales@foundationccc.org
916-425-8575



**FOUNDATION for CALIFORNIA
COMMUNITY COLLEGES**

*Benefiting, Supporting, and Enhancing
the California Community Colleges*

1102 Q Street, Suite 3500
Sacramento, California 95811-6549
Toll-Free Telephone: 866.325.3222
Facsimile: 916.325.0844
www.foundationccc.org

Lee Amundson
Krueger International (KI)
1330 Bellevue Street
P.O. Box 8100
Green Bay, WI 54308

April 7, 2015

Dear Ms. Amundson,

RE: Product Addition Request for CollegeBuys, Contract #CB13-013

This letter is to inform you that Krueger International (KI)'s Product Addition Request for the product line noted below has been approved, and may be procured by participating agencies at the same level of discounting in Exhibit B: Pricing and Product Information in **Contract #CB13-013** as indicated for the specific items below, per Item 13 of the General Provisions section of the agreement:

CB#13-013 Exhibit B: Product and Pricing Information			
Product Line	Classification	Application	Item(s)
Connection Zone (Benching, Storage, Screens and Dividers)	Administrative/Office Environment	Freestanding Tables & Desks	9.11
Connection Zone (Benching, Storage, Screens and Dividers)	Administrative/Office Environment	Office Storage	9.6
Connection Zone (Mobile Screens and Privacy Booths)	Administrative/Office Environment	Technology Tools	9.21

KI shall honor the enhanced warranty requirements outlined in Exhibit A: Mandatory Performance and Service Specifications for these approved product lines. The discounting levels shall apply as of the date indicated in this communication (Effective Date). Product addition information will be made available on the Foundation website.

In an effort to ensure that these product additions are communicated effectively, the Foundation recommends that KI:

- Communicate these product additions to all entities currently utilizing the contract.

(Continued on next page)



FOUNDATION *for* CALIFORNIA
COMMUNITY COLLEGES

*Benefiting, Supporting, and Enhancing
the California Community Colleges*

1102 Q Street, Suite 3500
Sacramento, California 95811-6549
Toll-Free Telephone: 866.325.3222
Facsimile: 916.325.0844

www.foundationccc.org

- Communicate the acceptance of these product additions to **Contract #CB13-013** to all participating agencies within thirty (30) days of approval.

If you have any questions or concerns please feel free to contact me directly. And thank you for your on-going support of our Community Colleges.

Sincerely,

Jorge J.C. Sales
Director of CollegeBuys
jsales@foundationccc.org
916-425-8575



County of Fairfax, Virginia

To protect and enrich the quality of life for the people, neighborhoods and diverse communities of Fairfax County

OCT 10 2012

Herman Miller, Inc.
855 East Main Ave
P.O. Box 302
Zeeland, MI 49464

Attention: Dave Gillman, Contract Manager

Reference: RFP200000330 – Office Furniture and Related Services and Solutions

Dear Mr. Gillman:

ACCEPTANCE AGREEMENT

Contract Number: 4400003403

This acceptance agreement signifies a contract award to Herman Miller, Inc. in its entirety for Office Furniture and Related Services and Solutions. The period of the contract is from January 1, 2013, through December 31, 2016, with four (4), one (1) year renewal options.

The contract award shall be in accordance with the following:

- 1) This Acceptance Agreement;
- 2) The signed Memorandum of Negotiations

Please note that this is not an order to proceed. A Purchase Order, which constitutes your notice to proceed, will be issued by the County. Please provide your Insurance Certificate according to Special Provisions paragraph 14 within ten (10) days of receipt of this letter. Contract award documents may be viewed on the Department of Purchasing and Supply Management website at www.fairfaxcounty.gov/cregister.

Cathy A. Muse, CPPO
Director/County Purchasing Agent

Department of Purchasing and Supply Management
12000 Government Center Parkway, Suite 427
Fairfax, VA 22035
Website: www.fairfaxcounty.gov/dpsm
Phone: 703-324-3201, TTY: 1-800-828-1140, Fax: 703-324-3228



County of Fairfax, Virginia

To protect and enrich the quality of life for the people, neighborhoods and diverse communities of Fairfax County

MEMORANDUM OF NEGOTIATION RFP2000000330

The County of Fairfax (hereinafter called the County) and Herman Miller, Inc. (hereinafter called the Contractor) hereby agree to the following in the execution of Contract 4400003403. The final contract contains the following items:

- a. Fairfax County's RFP2000000330
- b. All Addenda
- c. Herman Miller, Inc. Technical and Business proposal as amended by this Memorandum of Negotiations
- d. Response to clarifications dated August 7, and 8, 2012
- e. The Memorandum of Negotiations

The following and are to be included in the contract:

1. This contract will begin on January 1, 2013 and terminate on December 31, 2016. Fairfax County reserves the right to renew the contract for four (4) years, one (1) year at a time by mutual agreement.
2. Revised Cost Proposal Attachment A – Price Sheet – submitted via e-mail on August 9, 2012.
3. Discounts will remain firm for the duration of the contract. Discounts will be taken from the price books dated September 4, 2012 until new price books are released.

All other prices, terms, and conditions remain the same.

ACCEPTED BY:

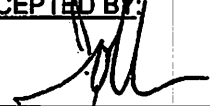

John Amrhein, Vice President of Operations
& North America Strategy Development
Herman Miller Inc.

10/2/12
Date

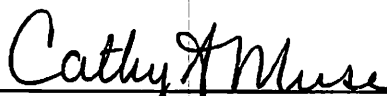

Cathy A. Muse, CPPO
Director/County Purchasing Agent

10/9/12
Date

DPSM OCT 31 2012 10:26

Department of Purchasing and Supply Management
12000 Government Center Parkway, Suite 427
Fairfax, VA 22035
Website: www.fairfaxcounty.gov/dpsm
Phone: 703-324-3201, TTY: 1-800-828-1140, Fax: 703-324-3228



County of Fairfax, Virginia

AMENDMENT

JAN 20 2015

AMENDMENT NO. 4

CONTRACT TITLE: Office Furniture and Related Services and Solutions

<u>CONTRACTOR</u>	<u>SUPPLIER CODE</u>	<u>CONTRACT NO.</u>
Herman Miller Inc. 855 East Main Ave. Zeeland, MI 49464	1000011666	4400003403

1. PRICE INCREASE

The purpose of this amendment is to notify all users that Herman Miller Inc. is implementing a price list adjustment of 1.7%, effective February 2, 2015. The new price list also includes new and refreshed fabrics, finishes and options.

2. ADD

	New Products		Discounts						
			\$0-\$100,000 List		\$100,000 - \$400,000 List				
	Dock		Inside	Basic Install	Expanded Install	Dock	Inside	Basic Install	Expanded Install
Layout Studio (A Flexible Bench Solution)	51%		49%	46%	44%	53%	51%	48%	46%
AGL Tables (Conference Room Table)	40%		38%	37%	35%	42%	40%	39%	37%
Herman Miller Collection (A group of design oriented products for office and lounge areas)	40%		38%	37%	35%	42%	40%	39%	37%

All other terms and conditions remain the same.

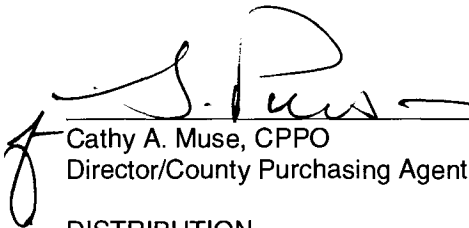
Cathy A. Muse, CPPO
Director/County Purchasing Agent

Steve Pierson, CPPB, VCO
Contracts Manager

DISTRIBUTION

Department of Finance – Accounts Payable
 Facilities Management Dept. –Christine Covey/e
 Facilities Management Dept. – Cathy Spaine/e
 Facilities Management Dept. – Rhinda Edwards/e
 U. S. Communities – Corey Imhoff – cimhoff@uscommunities.org

Contractor
 Contract Specialist – G. Bright
 Asst. Contract Specialist - Team 2

Department of Purchasing & Supply Management
 12000 Government Center Parkway, Suite 427
 Fairfax, VA 22035-0013

Website: www.fairfaxcounty.gov/dpsm

Phone (703) 324-3201, TTY: 1-800- 828-1140, Fax: (703) 324-3681



County of Fairfax, Virginia

AMENDMENT

AMENDMENT NO. 3

MAR 27 2014

CONTRACT TITLE: Office Furniture and Related Services

CONTRACTOR

Herman Miller Inc.
855 East Main Ave.
Zeeland, MI 49464

SUPPLIER CODE

1000011666

CONTRACT NO.

4400003403

By mutual agreement contract 4400003403 is amended as indicated below effective immediately.

Add:

New Products

Discounts

	\$0-\$100,000 List				\$100,000 - \$400,000 List			
	Dock	Inside	Basic Install	Expanded Install	Dock	Inside	Basic Install	Expanded Install
Renew Sit-to-Stand	67%	65%	62%	60%	69%	67%	64%	62%
Locale	58%	56%	53%	51%	60%	58%	55%	53%
Public Office Landscape	54%	52%	49%	47%	56%	54%	51%	49%

All other discounts, terms, and conditions remain the same.

Cathy A. Muse, CPPO
Director/County Purchasing Agent

Steve Pierson, CPPB, VCO
Contracts Manager

DISTRIBUTION

Department of Finance – Accounts Payable
Facilities Management Dept. – Bill Robinson/e
Facilities Management Dept. – Cathy Spaine/e
Facilities Management Dept. – Rhinda Edwards/e
Facilities Management Dept. – Christine Covey/e
U. S. Communities – Corey Imhoff – cimhoff@uscommunities.org

Contractor
Contract Specialist – G. Bright
Asst. Contract Specialist - Team 2

Department of Purchasing & Supply Management
12000 Government Center Parkway, Suite 427
Fairfax, VA 22035-0013

Website: www.fairfaxcounty.gov/dpsm

Phone (703) 324-3201, TTY: 1-800- 828-1140, Fax: (703) 324-3681



County of Fairfax, Virginia

AMENDMENT

DEC 20 2013

AMENDMENT NO. 2

CONTRACT TITLE: Office Furniture and Related Services and Solutions

CONTRACTOR

Herman Miller Inc.
855 East Main Ave.
Zeeland, MI 49464

SUPPLIER CODE

1000011666

CONTRACT NO.

4400003403

The purpose of this amendment is to notify all users that Herman Miller Inc. is implementing a price list adjustment of 2.6%, effective February 3, 2014. The new price list also includes new and refreshed fabrics, finishes and options.

All other terms and conditions remain the same.

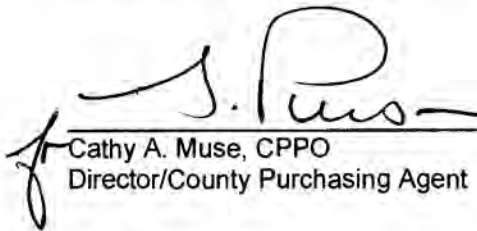
Cathy A. Muse, CPPO
Director/County Purchasing Agent

Steve Pierson, CPPB, VCO
Contracts Manager

DISTRIBUTION

Department of Finance – Accounts Payable
Facilities Management Dept. – Bill Robinson/e
Facilities Management Dept. – Cathy Spaine/e
Facilities Management Dept. – Rhinda Edwards/e
Facilities Management Dept. – Christine Covey/e
U. S. Communities – Corey Imhoff – cimhoff@uscommunities.org

Contractor
Contract Specialist – G. Bright
Asst. Contract Specialist - Team 2

Department of Purchasing & Supply Management
12000 Government Center Parkway, Suite 427
Fairfax, VA 22035-0013

Website: www.fairfaxcounty.gov/dpsm

Phone (703) 324-3201, **TTY:** 1-800- 828-1140, **Fax:** (703) 324-3681



County of Fairfax, Virginia

AMENDMENT

JUL 19 2013

AMENDMENT NO. 1

CONTRACT TITLE: Office Furniture and Related Services and Solutions

CONTRACTOR

Herman Miller Inc.
855 East Main Ave.
Zeeland, MI 49464

SUPPLIER CODE

1000011666

CONTRACT NO.

4400003403

By mutual agreement contract 4400003403 is amended as indicated below effective immediately. This change is for Fairfax County only.

Herman Miller Inc. is structured to sell their products through their distributors, therefore, Fairfax County is adding the following dealer to the contract. This dealer has been assigned their own contract number and supplier code.

This dealer is authorized to issue quotes, receive purchase orders, process, deliver and provide customer support in accordance with the discounts, terms, and conditions established with Herman Miller Inc.

Name of Dealer	Supplier Code	Contract Number
American Office of Gaithersburg Inc. 14801 Willard Road Chantilly, VA 20151 Contact: Denise Carlston, Director of Sales E-mail: dcarlston@americanoffice.com Telephone: 703-788-0800, ext. 237 Fax: 703-788-0805 Payment Terms: Net 30	1000000148	4400004122

This change in no way alters the responsibilities of Herman Miller, Inc. under the above referenced contract.

Cathy A. Muse, CPPO
Director/County Purchasing Agent

DISTRIBUTION

Department of Finance – Accounts Payable
Facilities Management Dept. – Bill Robinson/e
Facilities Management Dept. – Cathy Spaine/e
Facilities Management Dept. – Shirley Dowell/e
Facilities Management Dept. – Christine Covey/e
U. S. Communities – Corey Imhoff – cimhoff@uscommunities.org

Contractor
Contract Specialist – G. Bright
Asst. Contract Spec., Team 2

Department of Purchasing & Supply Management

12000 Government Center Parkway, Suite 427
Fairfax, VA 22035-0013

Website: www.fairfaxcounty.gov/dpsm

Phone (703) 324-3201, TTY: 1-800- 828-1140, Fax: (703) 324-3681



U.S. Communities Government Purchasing Alliance
Fairfax County, VA / US Communities Contract 4400003403
Effective February 2, 2015



Herman Miller, Inc., Price Sheet

Product Line	Discounts are from List Price Tiers are based on List Product Value of each order (except First Office) Discounts for orders over \$400,000 List Value are negotiable							
	\$1 - \$100,000				\$100,001 - \$400,000			
	Drop Ship	Inside Delivery	Basic Install	Exp'd Install	Drop Ship	Inside Delivery	Basic Install	Exp'd Install
Action Office® Systems, Ethospace® System, Quadrant B & F Front Pedestals, Eames® Tables (ET101 – ET308) and Avive® Tables, Erg. Comp. Furn.,	69%	67%	64%	62%	71%	69%	66%	64%
Canvas Office Landscape™ (Walls, Pvt. Off., Filing, Storage, Beam, Group)	69%	67%	64%	62%	71%	69%	66%	64%
Thrive Portfolio™, Public Office Landscape™	54%	52%	49%	47%	56%	54%	51%	49%
Layout Studio	51%	49%	46%	44%	53%	51%	48%	46%
Arrio®, Resolve®, Intersect™	53%	51%	48%	46%	55%	53%	50%	48%
Ergon 3® Seating, Equa 2® Seating,	57%	55%	54%	52%	59%	57%	56%	54%
Passage®, My Studio Environments™	50%	48%	45%	43%	52%	50%	47%	45%
Sense™ Desking System, Locale™	58%	56%	53%	51%	60%	58%	55%	53%
Meridian® Storage & Towers, Meridian® 5000 Series, Quad. B & F Front Lats	52%	50%	47%	45%	54%	52%	49%	47%
Meridian® Pedestals, Lateral & Vertical Files	54%	52%	49%	47%	56%	54%	51%	49%
Aeron® Seating, Mirra® 1 & 2, Celle™, Sayl™, Setu™ Chairs & Tables	51%	49%	48%	46%	53%	51%	50%	48%
Embodiy® Chair	49%	47%	46%	44%	51%	49%	48%	46%
Ambi® Seating, Caper® Seating, Limerick® Seating, Aside® Seating	53%	51%	50%	48%	55%	53%	52%	50%
Everywhere Tables™, Renew™ Sit-to-Stand Tables	67%	65%	62%	60%	69%	67%	64%	62%
Eames® Alum., Shell & Tandem Seating, Classical Seating, Collection, Celeste™ Seating, Burdick Group™, International Collection™, Swoop Lounge Furniture, Eames Stone-Top Tables	46%	44%	43%	41%	48%	46%	45%	43%
Tu™ Files, Tu™ Peds, Tu™ Storage, Tu™ Towers, Tu™ Laminate, Q Tables	65%	63%	60%	58%	67%	65%	62%	62%
Eames Molded Plastic and Wire, Goetz Sofa, Stools, Magis, Mattiazzi,	40%	38%	37%	35%	42%	40%	39%	37%
Co/Struc®, Action Lab™, Casework	51%	49%	46%	44%	53%	51%	48%	46%
Herman Miller for Healthcare Carts	12%	10%	7%	5%	12%	10%	7%	5%
Geiger® Caseloads and Seating, GeigerEXPRESS sm	51%	49%	46%	44%	52%	50%	47%	45%
SitOnIt® Products	54.5%	52.5%	51.5%	49.5%	58%	56%	55%	53%
	\$ 1 - \$ 25,000 (cust. sell @ dock discount)				\$ 25,001 - \$ 200,000 (cust. sell @ dock discount)			
First Office Products (Tiering based on FO products only)	54.7%	52.7%	49.7%	47.7%	59.7%	57.7%	54.7%	52.7%

- Purchase Orders must be issued to the local authorized Herman Miller dealer.
- List prices include freight within the 48 contiguous United States. Shipments outside of the contiguous United States are shipped freight prepaid to point of embarkation with freight costs beyond that point shipped collect.

Additional Services and Solutions	Hourly Rates	
	Min.	Max.
Installation of existing product	\$ 35.00	\$ 55.00
After hours installation	\$ 52.50	\$ 82.50
Design	\$ 55.00	\$ 75.00
Project Management	\$ 55.00	\$ 85.00
Asset Management	\$ 55.00	\$ 85.00
Refurbishment*	n/a	n/a
<i>*HMI or our dealer will work with the customer to determine the best product disposition via our rePurpose program or Trade-in</i>	To Be Quoted	
	Monthly Fee	
<i>Storage – for planning only, actual cost to be quoted; in/out and other services onsite and/or trailer storage are extra</i>	\$1.40/sq. ft.	\$1.80/sq. ft.
Other Related Services and Solutions	Hourly Rates	
	Min.	Max.
Reconfiguration	\$ 35.00	\$ 55.00
Strategic Planning Services	\$ 100.00	\$ 150.00
Occupancy Planning/CAD Drafter	\$ 60.00	\$ 85.00
Build-Out Project Mgt. Services	\$ 90.00	\$ 110.00
FF&E Mgt. Services	\$ 90.00	\$ 110.00
<i>*Travel expenses will be quoted extra</i>		
Performance Environments – (Ref Attach.)	To Be Quoted	

Note:

1. **Drop Ship**, price includes product delivery to the site, the purchaser is responsible for unloading.
2. **Inside Delivery**, price includes product delivered to the site and unloaded.
3. **Basic Installation**, price includes inside delivery, uncrating, assembly, installation, removal of debris from premises, installation documents and the bill of materials per the purchaser's approved plan and specifications.
4. **Expanded Service Installation** price to include basic installation; field measurements surveyed, documented and coordinated; electrical and tele/data infeed locations are surveyed, documented and coordinated; attend required coordination meetings with purchaser and other contractors; and creation and implementation of punch list by project manager.

Installation & Delivery Services:

The service option product discounts include "standard" services only, subject to the conditions listed below. The discounts are "not to exceed" percentages that may be lower as quoted by the servicing dealer dependent on the specific project conditions. Additional charges and services shall be negotiated in advance of the service being performed.

- Installation will be performed during normal weekday working hours.
- Adequate facilities for delivery, unloading, moving and staging/storing the product during the installation process shall be provided.
- Service work will shall not be hindered by other trades.
- Electric, heat, and adequate elevator service will be furnished without charge.
- The immediate installation area shall be complete and free of debris including the carpet/flooring before installation commences.
- Any work requiring a licensed electrician is the responsibility of the buyer.

Additional Charges May Apply For:

- 1) Orders of an aggregate quantity of 1 - 10 chairs, desks, files, peds - NTE \$300 fee per delivery.
- 2) Major Metro Markets and any non-ground floor installation: NTE 1% - 3.5% of list product value
- Major Metro Markets include large population centers and urban environments.
- 3) Installation in a clinical/medical environment: NTE 1% - 3.5% of list product value
- 4) Special restrictions or limits established by local laws, ordinances or the directions of the buyer, including but not limited to restrictions on transportations of materials, street access to the job site and/or dock facilities: NTE 1% - 3.5% of list product value
- 5) Installations outside of a 50 mile radius of the servicing dealer: NTE 1% - 2% of list product value.
- 6) Local Prevailing Wage and/or Union Labor Rates

Any additional charges shall be quoted by the dealer and approved by the buyer prior to performance of the work.

NTE = Not To Exceed