

STRUCTURAL EVALUATION OF

**SOLANO COMMUNITY COLLEGE  
THEATER BUILDING**

Fairfield, California

For

**tBP Architects**  
Concord, CA

By

**DASSE Design, Inc.**  
555 12<sup>th</sup> Street, Suite 600  
Oakland, CA 94607

DASSE Design Project No. 08B173

May 29, 2008

## TABLE OF CONTENTS

	Page No.
1.0 EXECUTIVE SUMMARY .....	2
2.0 INTRODUCTION .....	3
3.0 BUILDING DESCRIPTION .....	3
4.0 FINDINGS .....	4
5.0 PROPOSED SEISMIC STRENGTHENING .....	5
6.0 CONCLUSIONS AND RECOMMENDATIONS .....	6
7.0 DOCUMENTS REVIEWED .....	6
8.0 LIMITATIONS AND DISCLAIMER .....	6
9.0 APPENDIX – BUILDING PHOTOS .....	7

## LIST OF SKETCHES (SKS)

- Sketch #1: Ground Floor Retrofit Plan
- Sketch #2: Roof Retrofit Plan
- Sketch #3: Additional Roof Nailing Plan
- Sketch #4: Stage Block Wall Retrofit - Elevation
- Sketch #5: Stage Block Wall Retrofit - Detail
- Sketch #6: Plan of New Collector Connection
- Sketch #7: Typical Collector Connection
- Sketch #8: (N) Wall Anchor at Auditorium Roof
- Sketch #9: (N) Blocking and Nailing at Auditorium Roof
- Sketch #10: (N) Wall Anchor at Auditorium Roof
- Sketch #11: (N) Brace for Control Room
- Sketch #12: Connection Detail for (N) Brace at Control Room
- Sketch #13: (N) Wall Out-Of-Plane Connection Detail
- Sketch #14: (N) Wall Out-Of-Plane Bracing Truss

## 1.0 EXECUTIVE SUMMARY

A structural evaluation consisting of a site walk-through, a review of architectural and structural drawings, and limited independent structural calculations has been performed for the Solano Community College Theater Building. The scope of the evaluation was not to verify every member and detail, but to focus on those elements of the structure determined to be most important, relative to its seismic performance during a major earthquake. The structural evaluation focused on issues related to compliance with code minimum structural requirements (2007 CBC, Title 24 CCR) and to achieve Life Safety performance level. Strengthening of items identified would make those items code compliant (2007 CBC, Title 24 CCR).

The Theater Building Complex consists of an auditorium structure with an adjacent one story Music/Shop Building and was constructed in 1973. There is a 1 ½" seismic gap between the auditorium and the adjacent structure. The lateral system typically consists of exterior tilt-up concrete shear walls with a plywood diaphragm at the roof level.

The building framing system was determined to have the following seismic deficiencies when subjected to seismic force levels and detailing requirements of the 2007 CBC:

1. The Control room floor located above the main entrance lobby needs lateral bracing in the transverse direction. This floor diaphragm lacks lateral bracing.
2. The existing shear walls on gridline 10 and between grids A to C and E to G are overstressed for shear. Additionally, these walls need to be strengthened to resist wall overturning moments.
3. The low roof diaphragm between gridlines 9/13 and G/L needs a new collector line on gridline 13 to resist diaphragm shear and to drag the lateral load into shear wall on line 13.
4. The roof diaphragm of the Music/Shop building is overstressed and needs a new collector on gridline 16 & 23 between grids A to D and D to G.
5. Connections of the exterior concrete shear wall to the diaphragm need to be strengthened all around both buildings to resist wall out-of-plane seismic forces.
6. The Auditorium and Music buildings roof diaphragm edge nailing is overstressed and needs to be strengthened around the perimeter and at interior collector lines of both buildings.
7. Existing mezzanine in the Shop building (currently used as office) needs to be seismically retrofitted.

8. Existing suspended plaster ceiling in the Auditorium building has no lateral bracing.

Seismic strengthening of the above noted seismic deficiencies on a voluntary basis should not trigger a mandatory seismic upgrade of the entire building.

## 2.0 INTRODUCTION

A structural evaluation of the construction documents (see Section 7.0) furnished to DASSE has been performed for the Solano Community College Theater Building. The review included a walk-through of the existing building, a qualitative appraisal of the plans and details, and independent calculations using the vertical and lateral load requirements of the 2007 California Building Code (Title 24 CCR). The scope was not to verify every member and detail, but rather to focus on those elements of the structure determined by DASSE to be most important and most representative of the general design and constructed quality. Recommendations provided in this report are intended to mitigate seismic life safety risks in the event of a moderate to major earthquake by strengthening the lateral systems on a voluntary basis. Strengthening of the elements of the lateral system outlined in this report does not ensure complete code compliance of the entire building, but would significantly improve the performance of the building to achieve the goal stated above.

## 3.0 BUILDING DESCRIPTION

The Theater Building Complex consists of a auditorium structure with an adjacent one story Music/Shop Building and was constructed in 1973. There is a 1 ½" seismic joint between the Auditorium and the Music/Shop Building.

The Auditorium is a tall one story building and has a stage with a high roof at the north end and a low roof Make-Up room area on the west side. The Music and Shop/Storage Building is adjacent to the auditorium building and is separated by a 1 ½" seismic gap between the two buildings.

The lateral system for the Auditorium consists of exterior concrete tilt-up panels with poured-in-place concrete pilasters. The roof framing consists of steel wide flange beams in the east-west direction with a one inch plywood roof acting as a diaphragm to resist lateral loads. The Control room floor above the front canopy has wood framing and part of the floor is supported by W4x13 posts hung from the roof and lacks lateral bracing.

The ceiling of the Auditorium consists of suspended plaster ceiling and lacks lateral bracing in longitudinal and transverse direction.

The grid-iron level has steel framing supporting the stage props. The high roof over the grid-iron level has steel framing with concrete diaphragm.

The Music and Shop/Storage Building's lateral system is similar to that of the Auditorium building (i.e. concrete tilt-up panels with poured-in-place concrete pilasters). The roof framing consists of open web joists with a plywood diaphragm.

#### 4.0 FINDINGS

##### 4.1 General

The building lateral system was checked based on the 2007 CBC (Title 24 C.C.R.) Code. The intent of the code is to provide criteria for the seismic performance of the building in the event of a moderate to major earthquake (10% chance of exceedance in 50 years with a 475 year return period) so as to provide for life safety.

The site is in an active seismic zone. The nearest known active fault and its distance to the site are:

Concord Green Valley Fault (Class B)                      7 Km West

It is reasonable to assume the building will be subjected to strong ground shaking from a moderate to major earthquake at least once during the remaining life of the building.

##### 4.1 Lateral Force Resisting System

1. The Control room floor diaphragm lacks lateral bracing in the north-south direction. The current diaphragm aspect ratio is approximately 7:1 which exceeds the code allowable value of 3:1.
2. The existing shear walls at gridline 10 between grids A to C and E to G are overstressed in the lower level due to wall overturning moments and need to be strengthened.
3. The low roof diaphragm of the Auditorium Building between gridlines 9/13 and G/L needs a new collector line on gridline 13 to resist diaphragm shear and to drag the lateral load into the shear wall on line 13.
4. The low roof diaphragm of the Music Building is overstressed and needs a new collector on gridline 23. This collector will in turn drag the seismic loads into the shear wall on gridline 23.
5. Connection between the poured-in-place exterior concrete pilasters and the roof diaphragm needs to be strengthened as they are currently inadequate to resist wall out-of-plane forces. This is required all around the perimeter of both buildings.

6. The Auditorium roof diaphragm edge nailing is overstressed and needs to be strengthened along gridlines 1, 10, A and G. Similarly the Music building roof diaphragm edge nailing is also needs overstressed.
  7. The existing mezzanine level within the Shop building, which is currently being used as office space, lacks lateral system to resist seismic loads and needs to be retrofitted. No structural and architectural drawing for this office area was provided and it is unknown whether this was constructed with the DSA approval.
- 4.2 The Auditorium ceiling lacks lateral bracing. Provide new unistrut lateral bracing to adequately brace the existing suspended plaster ceiling.

## 5.0 PROPOSED SEISMIC STRENGTHENING

### 5.1 Seismic Strengthening

Strengthening measures to mitigate the seismic deficiencies identified in Section 4.1 and 4.2 are described below (in the same order) and in attached sketches. It is anticipated that temporary relocation of existing duct work will be involved during the implementation of the proposed seismic strengthening at certain locations.

1. Provide lateral bracing in the north-south direction as shown in sketch numbers 1, 11 and 12
2. Provide new shotcrete walls to strengthen existing shear walls on gridline 10 as shown in sketch numbers 1, 4 and 5.
3. Provide new collector member as shown in sketch numbers 2, 6 and 7. Also, provide new nailing along the collector line as shown in sketch number 3.
4. Provide new collectors on gridline 23 as shown in sketch number 2. Also, provide new nailing along the collector line as shown in sketch number 3.
5. Provide new wall out-of-plane ties for the Auditorium building as shown in sketch numbers 2, 8, 9 and 10.
6. Provide additional nailing as shown in sketch number 3 for the Auditorium building, Make-Up room and the Music building.
7. Provide new plywood shear wall, hold-downs and attachment to the existing concrete wall.
8. Provide new unistrut lateral bracing at 8'-0" on center in both directions.

## 6.0 CONCLUSIONS AND RECOMMENDATIONS

We recommend that the deficiencies identified in Section 4.2 and seismic strengthening proposed in Section 5.1 be implemented at the minimum, in order to achieve a Life Safety performance level as defined in the 2007 CBC (Title 24, C.C.R.). The seismic retrofit solution shown in the sketches are schematic (conceptual) and are for the purposes of obtaining a cost estimate (by others). It is assumed that a more detailed analysis and review of proposed seismic retrofit solution will be carried out at a later stage.

## 7.0 DOCUMENTS REVIEWED

Solano County Junior College Music and Little Theater Building – As-Built Existing Architectural and Structural Drawings dated March 30, 1973, by Delp W. Johnson, Poole & Storm – Architects Associated, San Francisco, California

Architectural drawings sheet numbers A-0 through A-17 and structural drawings sheet numbers S-1 through S-9 and SD-1 (Note SD-2 is missing and was not reviewed).

Drawings for the office mezzanine area were missing and hence were not reviewed.

It appears that the front entrance canopy structure was not constructed as shown in the structural drawing between grid lines A to G and lines 1 to 0 based on the site visit and review of the photographs of this area.

## 8.0 LIMITATIONS AND DISCLAIMER

The scope of this investigation was to focus on those elements of the structure considered most important, most frequently overlooked and most representative of the general design and constructed quality. Users of this report must accept the fact that deficiencies may exist in the structure that were not observed in this evaluation. Our services have consisted of providing professional opinions, conclusions, and recommendations based on generally accepted structural engineering principles and practices.

The existing structural drawings were hard to read and in certain locations were illegible. The actual plywood thickness at the Auditorium roof has to be field verified as it is not clear from the existing structural drawings whether it is ½” thick or 1” thick plywood sheathing.

9.0 APPENDIX – BUILDING PHOTOS



Photo 1 Aud. Ceiling



Photo 2 Aud. Ceiling





Photo 3 Aud. Ceiling



Photo 4 Control Room



Photo 5 Aud. Ceiling (from below)



Photo 6 Void Space above Ticket Window



Photo 7 Front Entrance



Photo 8 Shop Office



Photo 9 Shop Office 2



Photo 10 Central Corridor

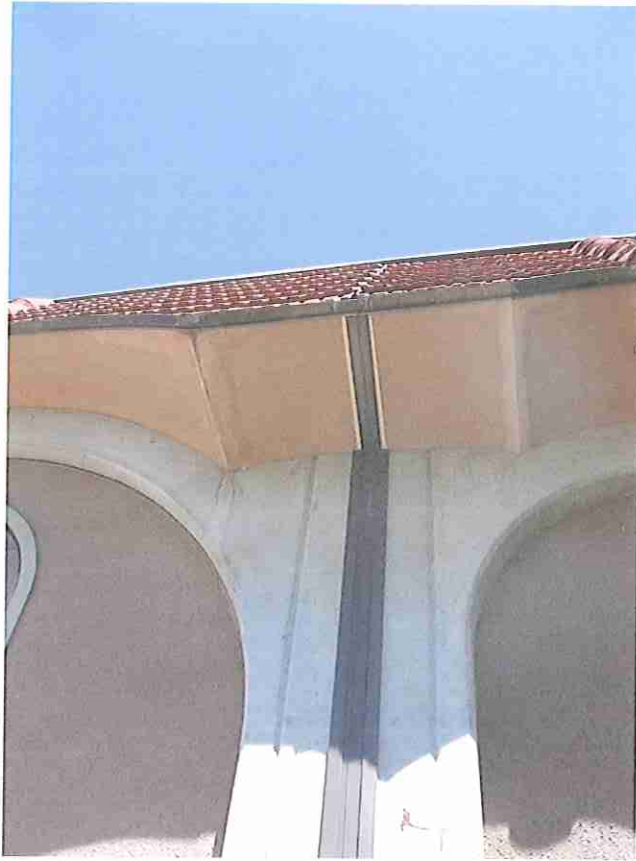
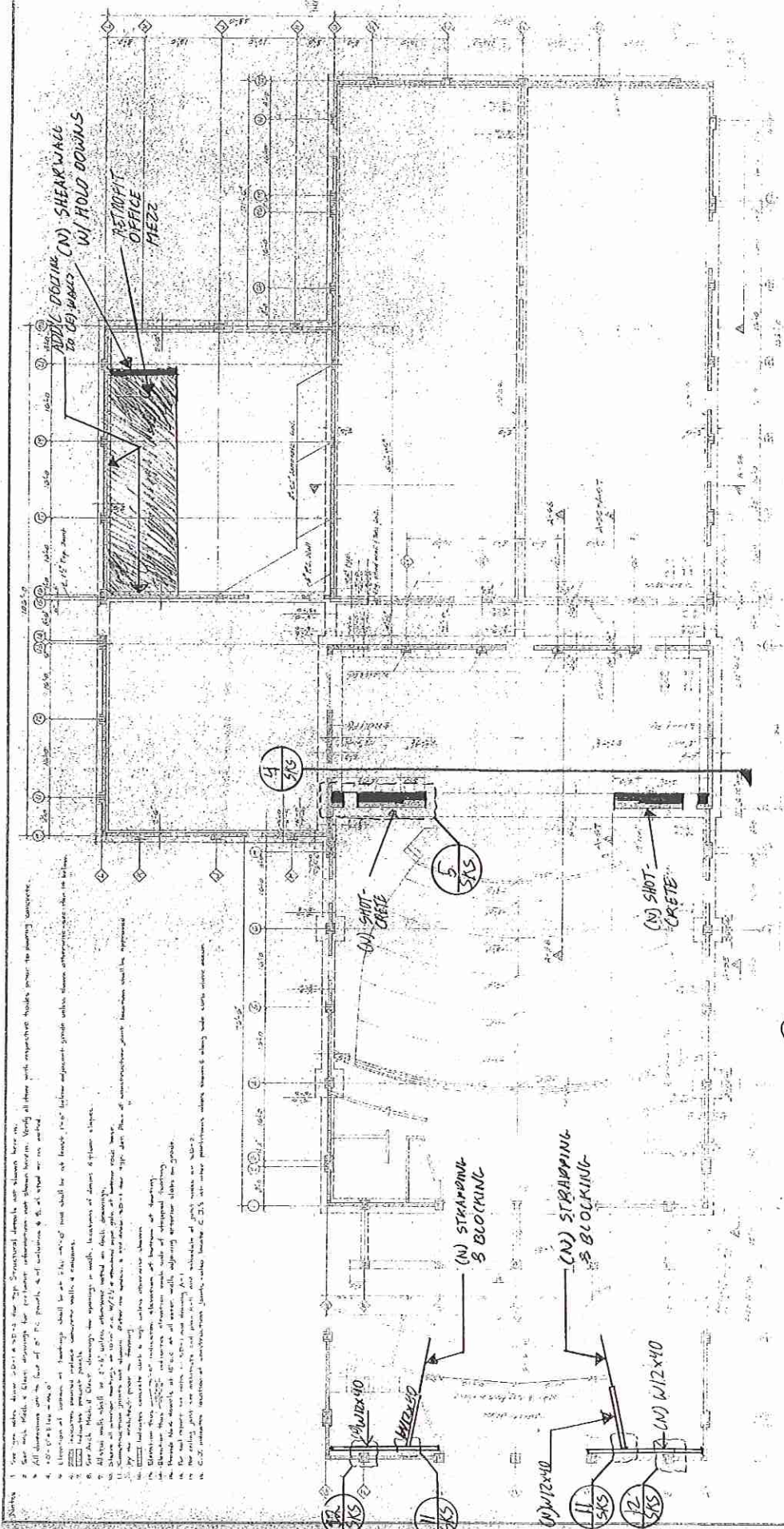

Photo 11 Seismic Gap



Photo 12 Stage Block



1. See notes above sheet 201-1-11 for structural details and dimensions.
2. See notes 1011 & 1012 regarding performance requirements and dimensions. Verify all dimensions with the architect.
3. All dimensions are in feet and inches.
4. 1/4" = 1'-0" unless otherwise noted.
5. Dimensions of columns at locations where spacing is noted.
6. Dimensions of columns at locations where spacing is noted.
7. All steel work shall be A36 unless otherwise noted on detail drawings.
8. All steel work shall be A572 unless otherwise noted on detail drawings.
9. All steel work shall be A572 unless otherwise noted on detail drawings.
10. All steel work shall be A572 unless otherwise noted on detail drawings.
11. All steel work shall be A572 unless otherwise noted on detail drawings.
12. All steel work shall be A572 unless otherwise noted on detail drawings.
13. All steel work shall be A572 unless otherwise noted on detail drawings.
14. All steel work shall be A572 unless otherwise noted on detail drawings.
15. All steel work shall be A572 unless otherwise noted on detail drawings.
16. All steel work shall be A572 unless otherwise noted on detail drawings.
17. All steel work shall be A572 unless otherwise noted on detail drawings.
18. All steel work shall be A572 unless otherwise noted on detail drawings.
19. All steel work shall be A572 unless otherwise noted on detail drawings.
20. All steel work shall be A572 unless otherwise noted on detail drawings.

**SKS-1 GROUND RETROFIT PLAN**

WILLIAM JOHNSON & SONS, INC. - DALLAS, TEXAS  
 ARCHITECTS & ENGINEERS  
 SOLANO COUNTY JUNIOR COLLEGE  
 SOLANO COUNTY JUNIOR COLLEGE DISTRICT  
 PROJECT NO. 1011-1-11

DATE: 10/1/71  
 DRAWN BY: J. SMITH  
 CHECKED BY: J. SMITH  
 APPROVED BY: J. SMITH

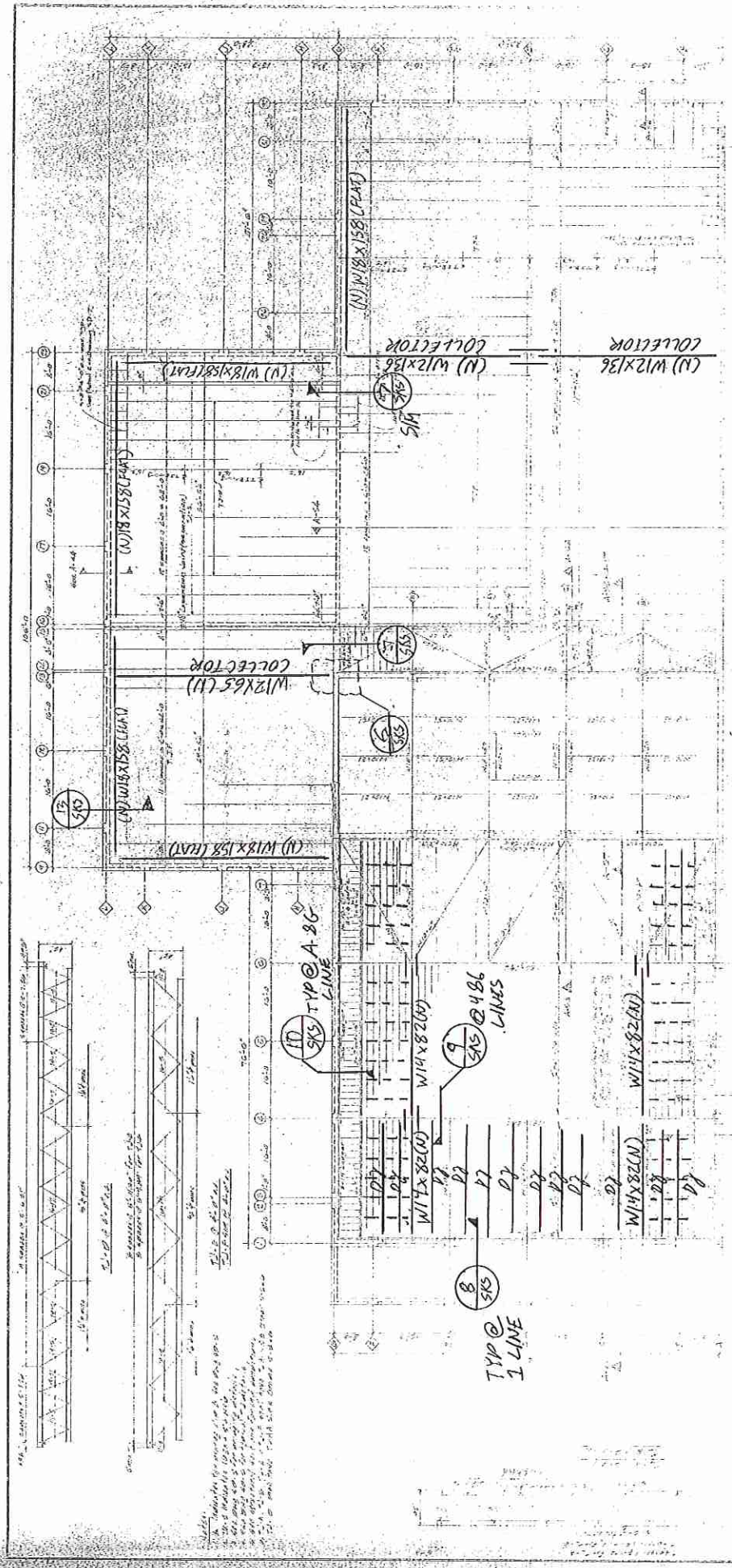

D7 - DOUBLE JOIST SKS-2 ROOF RETROFIT PLAN

SOLANO COUNTY JUNIOR COLLEGE

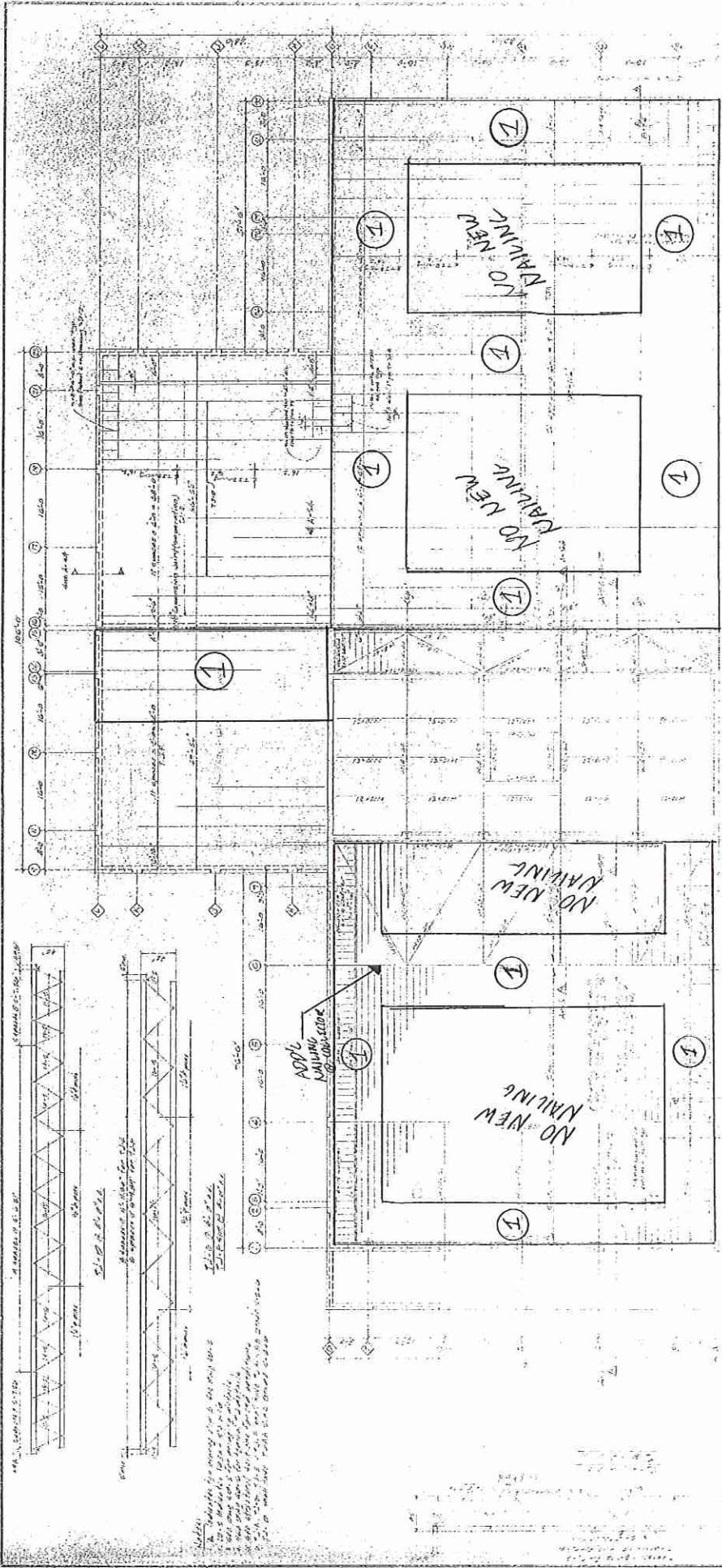

① ADD NAILING TILL 10d @ 4" O.C. 2 ROWS @ EDGE  
10d @ 12" O.C. FIELD

SKS-3 ADD'L ROOF NAILING PLAN

SCLAND COUNTY JUNIOR COLLEGE



# DASSE

DASSE DESIGN INC.  
STRUCTURAL ENGINEERS

San Francisco  
Oakland

PROJECT SCT

JOB No. 088173 By TMW

DATE 5/28/08 PAGE SKS-4

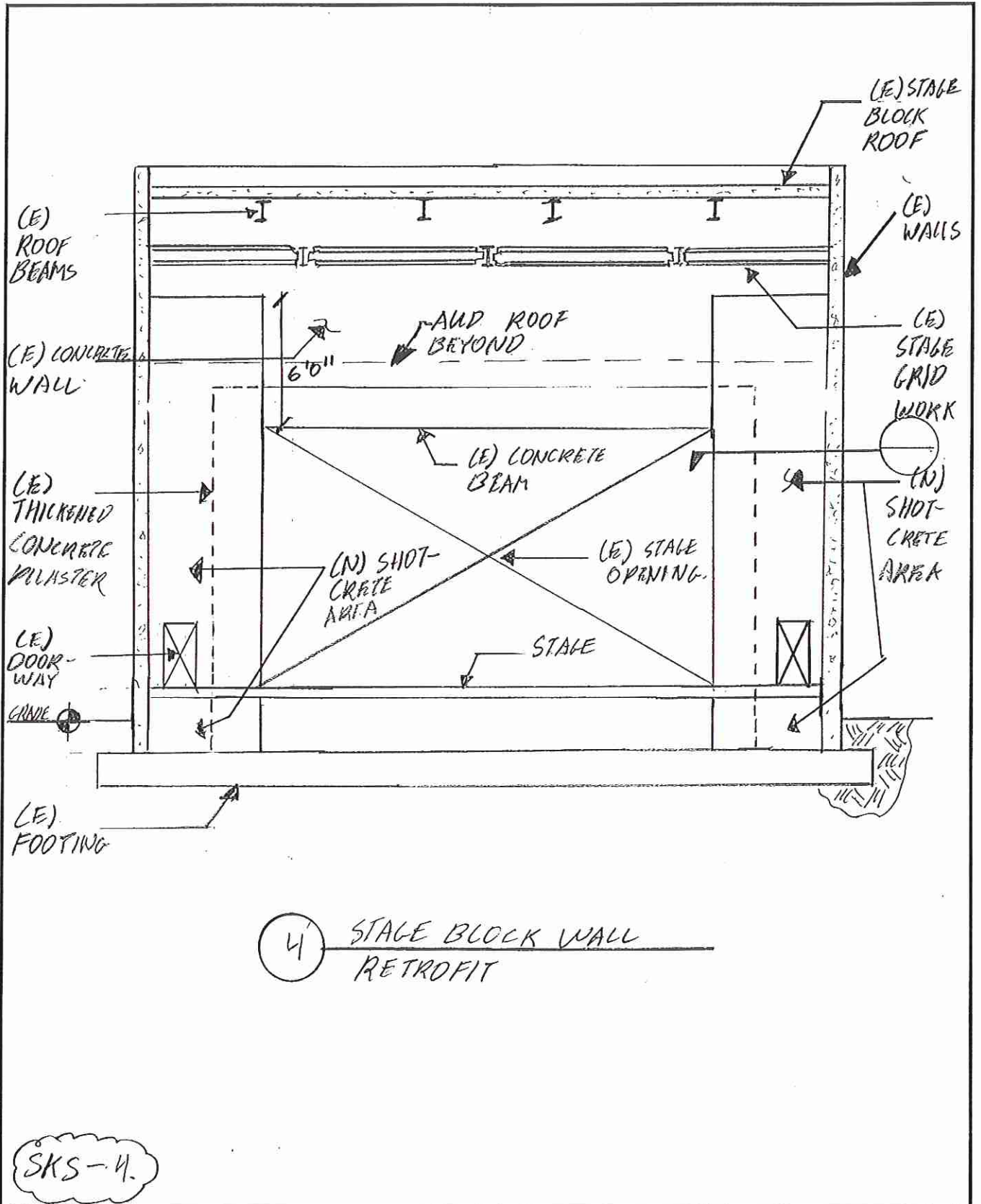

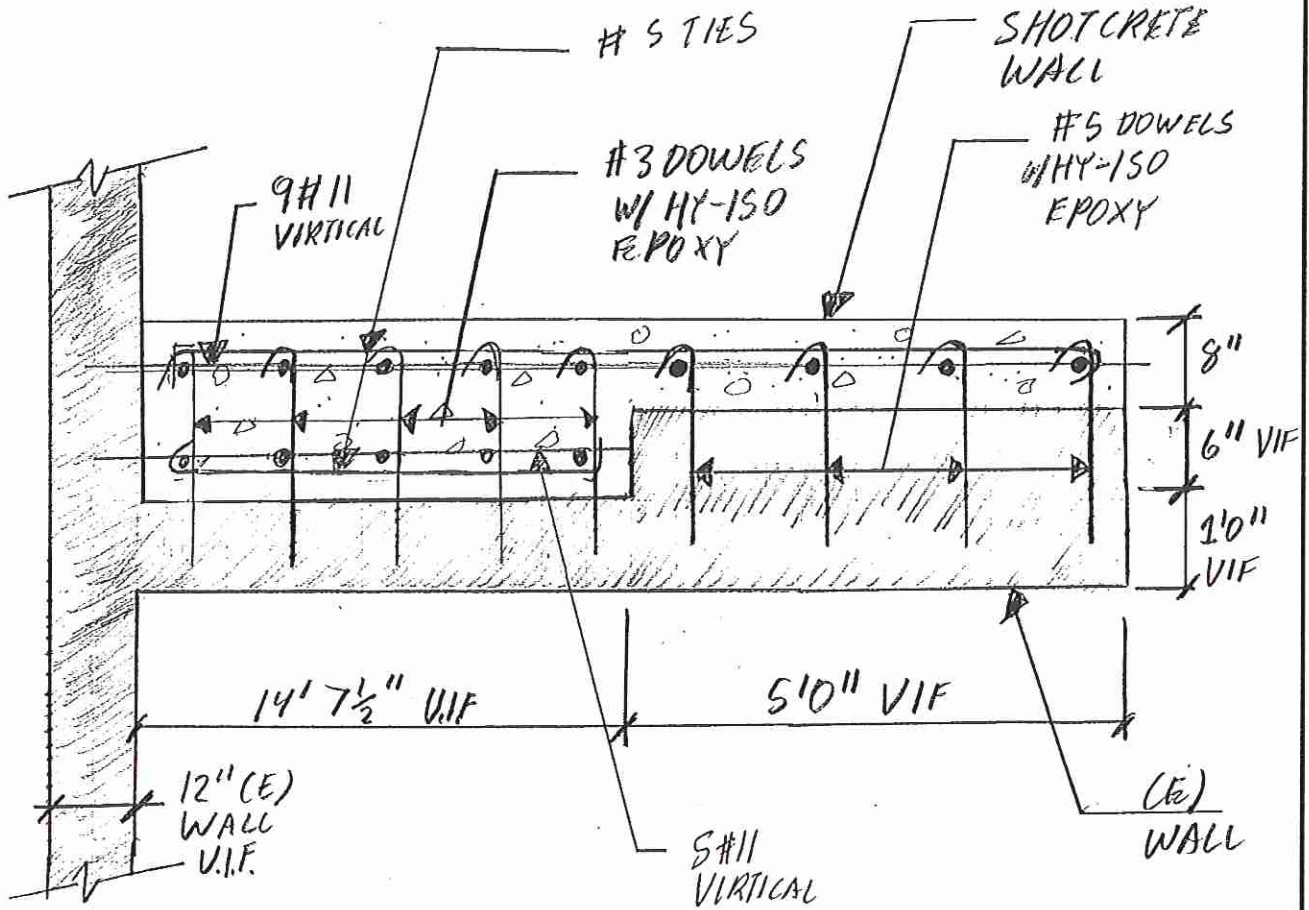

⑤ RETROFIT OF (CE) STAGE BLOCK WALL PIER

SKS-5

# DASSE

DASSE DESIGN INC.  
STRUCTURAL ENGINEERS

San Francisco  
Oakland

PROJECT SCT

JOB No. 08B173 BY TMW

DATE 5/28/08 PAGE SKS-6

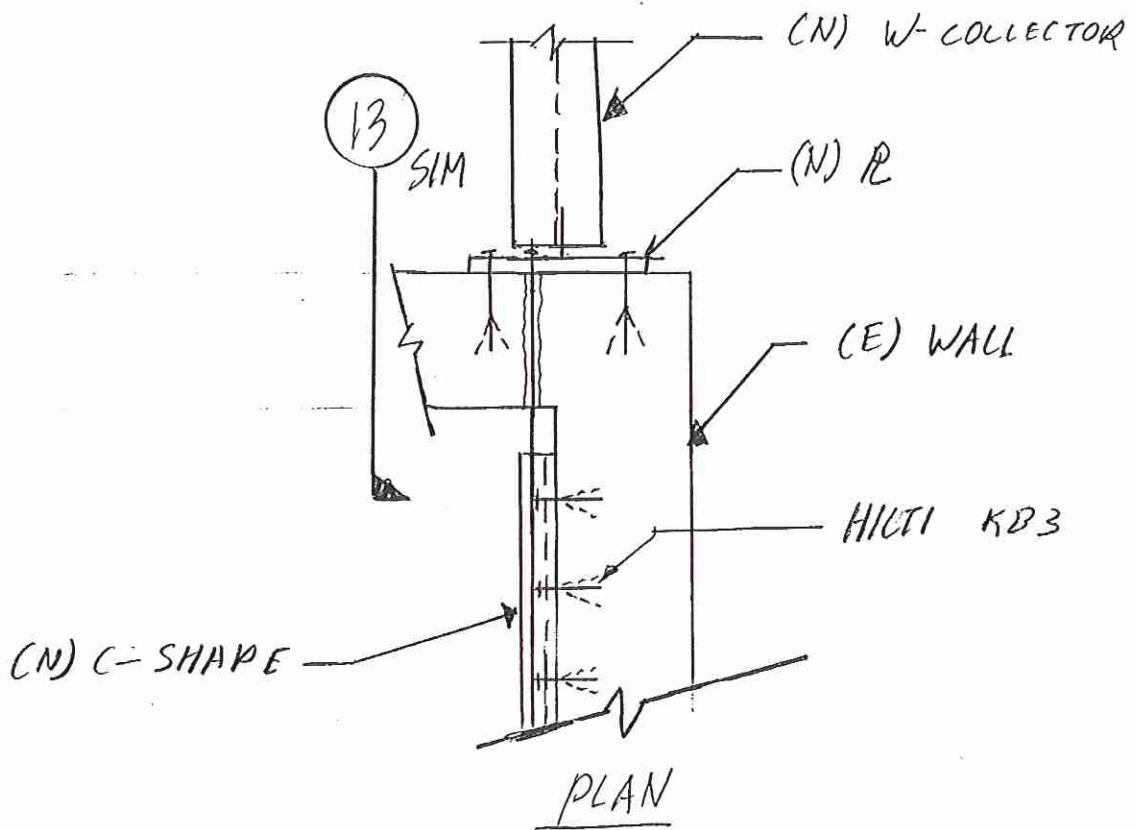

⑥ TYP COLLECTOR  
ANCHOR CONNECTION

SKS-6

# DASSE

DASSE DESIGN INC.  
STRUCTURAL ENGINEERS

San Francisco  
Oakland

PROJECT SCT

JOB No. 080173 BY TMW

DATE 5/28/08 PAGE SKS-7

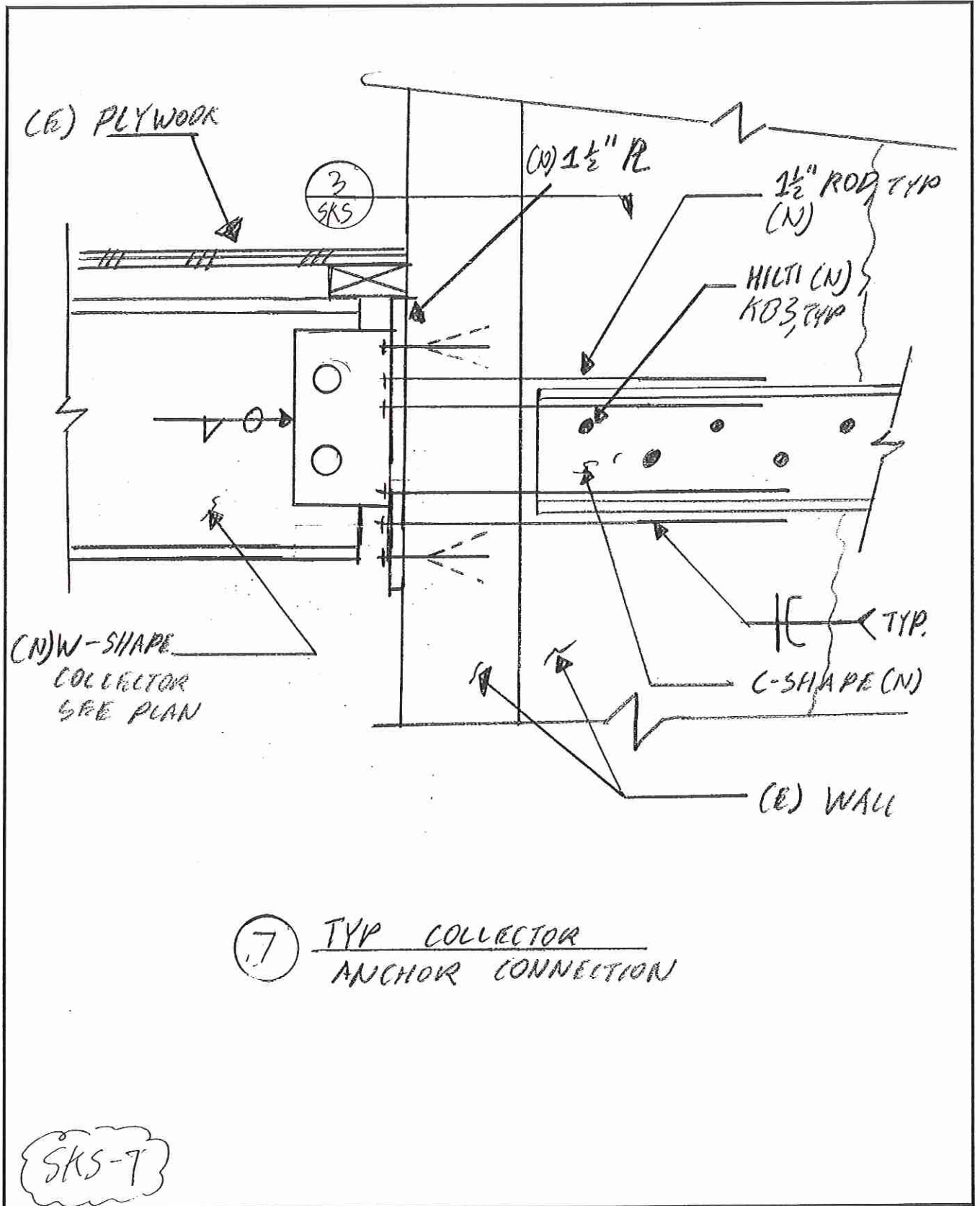

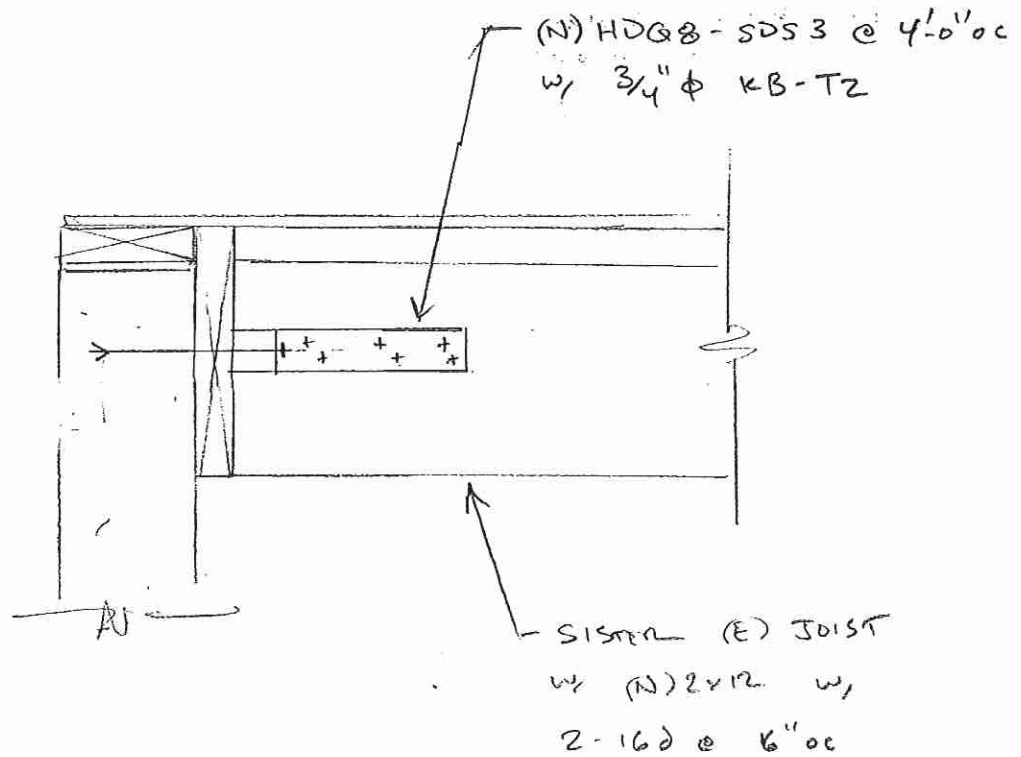

⑧ (N) WALL ANCHOR @ 4'-0" oc AT  
- ADD. ROOF, PARALLEL TO (E) JOIST

SKS-8

# DASSE

San Francisco  
Oakland

DASSE DESIGN INC.  
STRUCTURAL ENGINEERS

PROJECT SCT

JOB No. 08B173 BY TMW

DATE 5/28/08 PAGE SK8-9

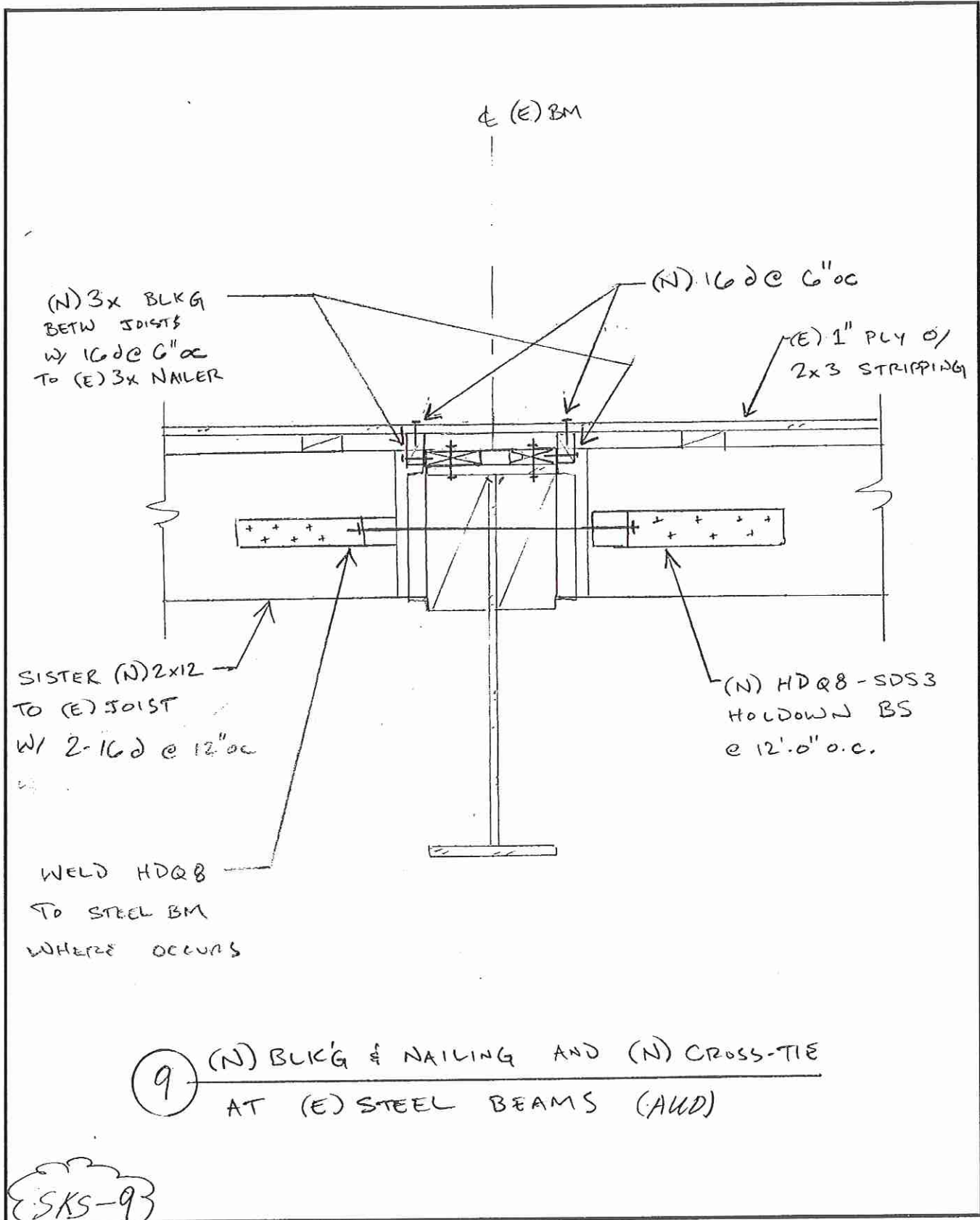

SISTER (N) 2x12  
TO (E) JOIST  
W/ 2-1G @ 12" OC

WELD HDQ8  
TO STEEL BM  
WHERE OCCURS

9 (N) BLKG & NAILING AND (N) CROSS-TIE  
AT (E) STEEL BEAMS (ADD)

SKS-9

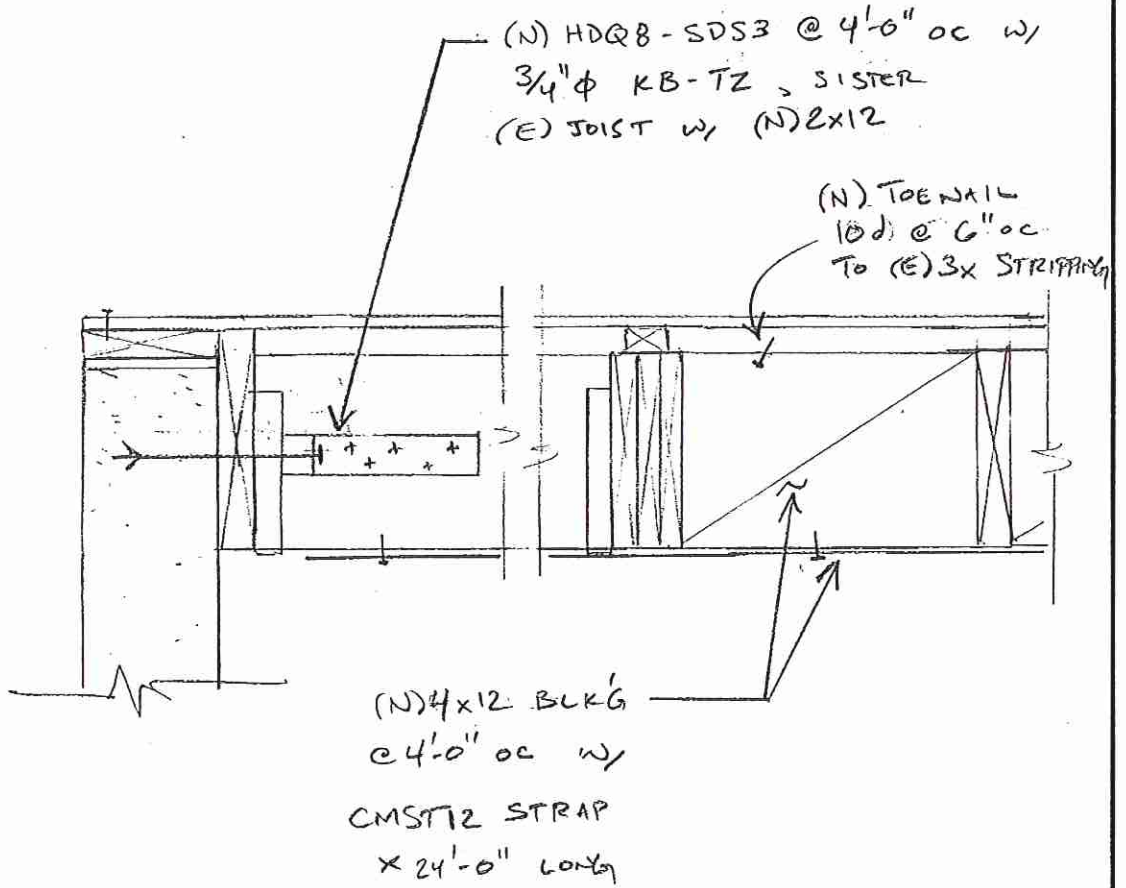

⑩ (N) WALL ANCHOR @ 4'-0" oc AT  
ADD. ROOF, PERPENDICULAR TO (E) JOIST

SKS-10

# DASSE

DASSE DESIGN INC.  
STRUCTURAL ENGINEERS

San Francisco  
Oakland

PROJECT SCT

JOB NO. 08B173 BY TMW

DATE 5/28/08 PAGE SKS-11

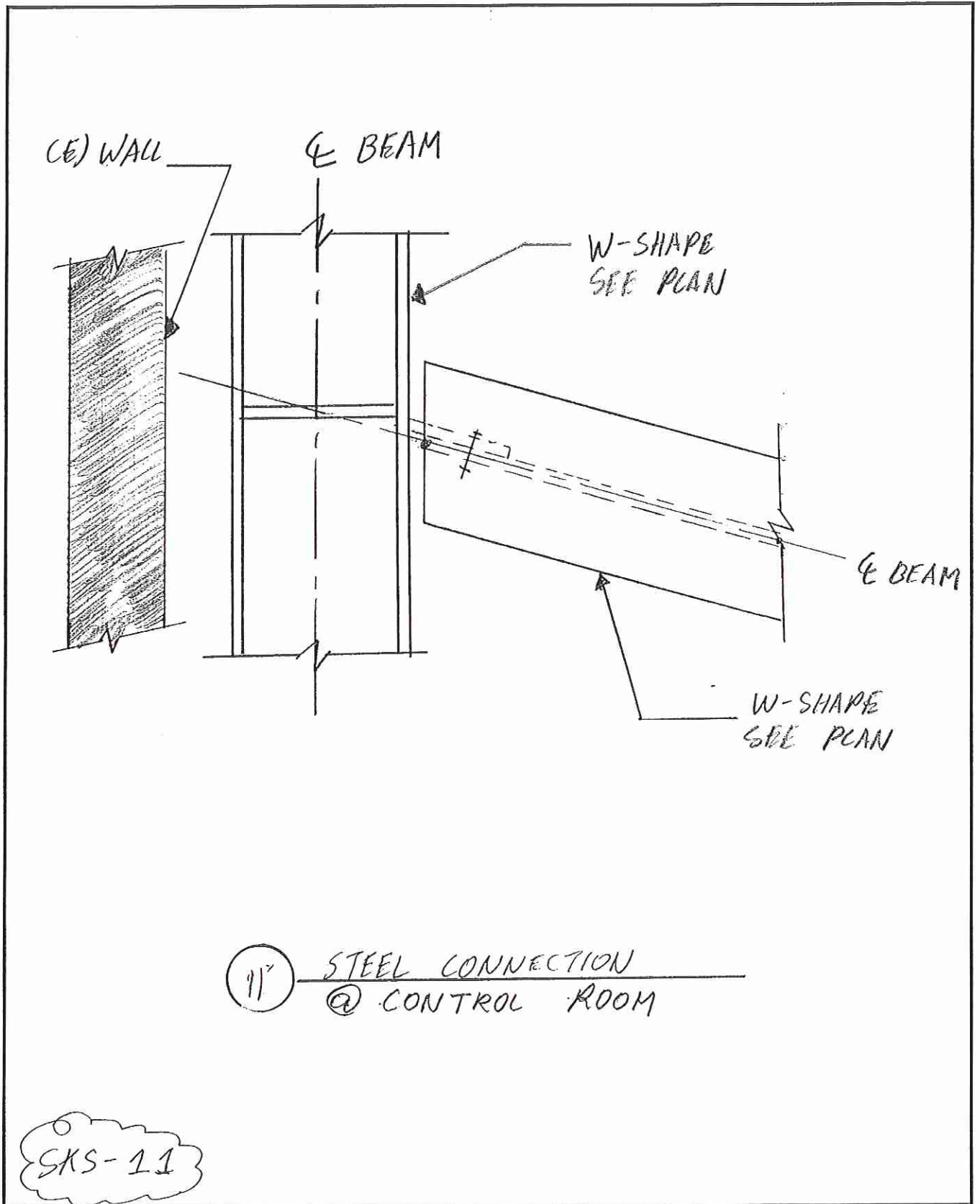

11' STEEL CONNECTION  
@ CONTROL ROOM

SKS-11



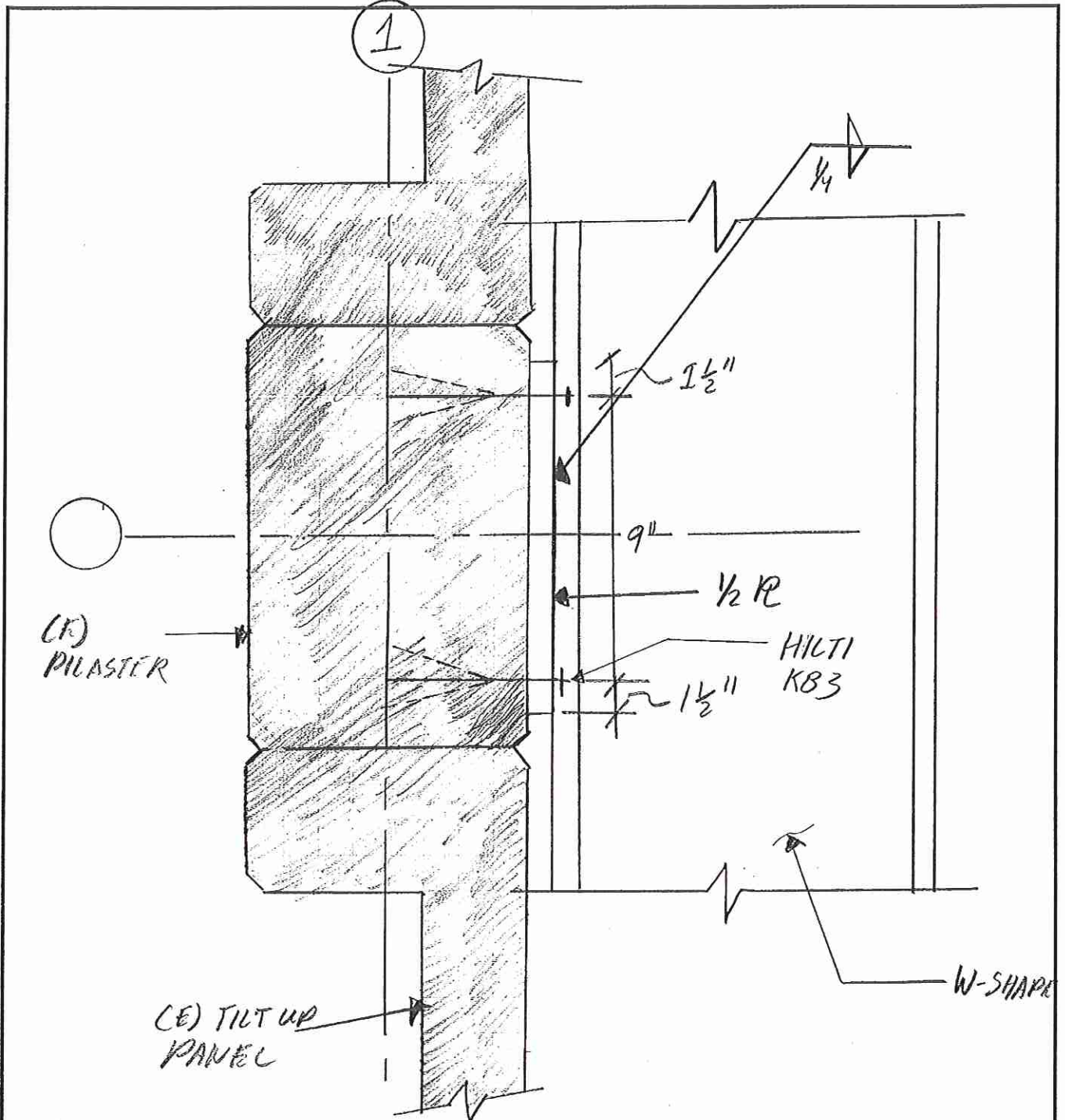

12 CONNECTION AT (F) PILASTER  
@ CONTROL ROOM

SKS-12

